

Z32X-KNCK

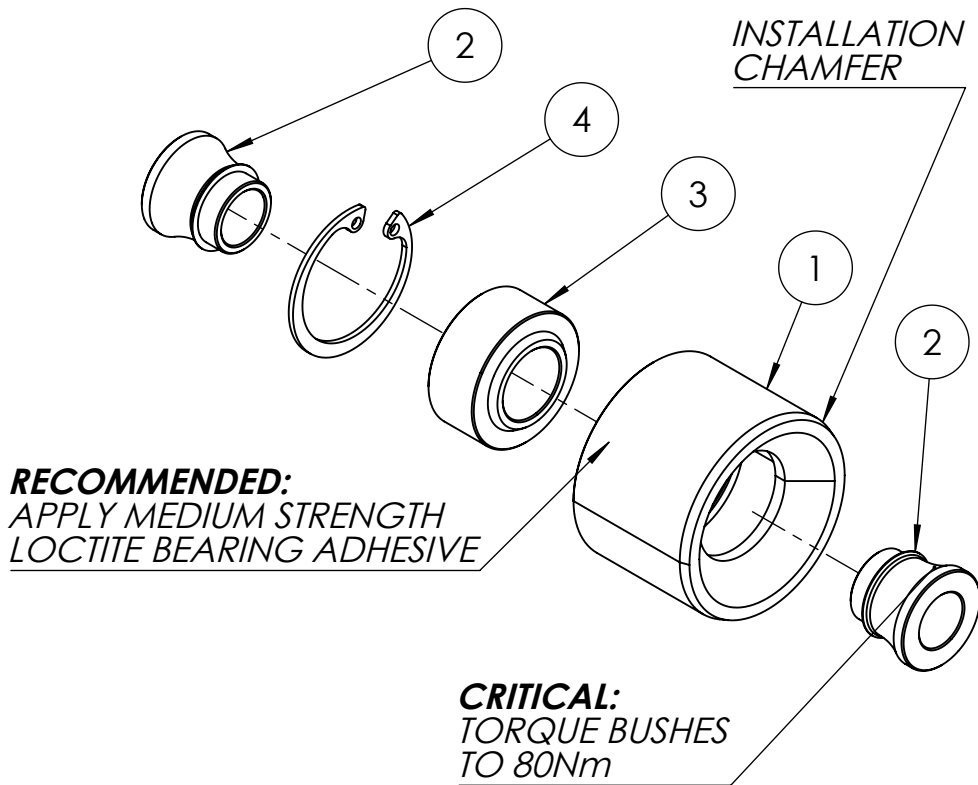

DIAGRAM A

1. PRESS OUT THE OEM BUSHINGS.
2. APPLY LOCTITE BEARING ADHESIVE.
(MEDIUM STRENGTH IS SUFFICIENT) *RECOMMENDED.
3. PRESS IN NEW SPHERICAL BEARINGS USING THE
INSTALLATION CHAMFER. PRESS THE HOUSING IN BY
APPLYING FORCE ON THE OUTER EDGE.

ITEM NO.	DESCRIPTION:	QTY:
1	Z32 REAR KNUCKLE DAMPER SP. ADAPTER	1
2	COM10T SPACER 12.2X41.75 - MM	2
3	COM10-T SPHERICAL BEARING	1
4	DIN 472 INTERNAL RETAINING RING	1