

MIN ADJUSTMENT

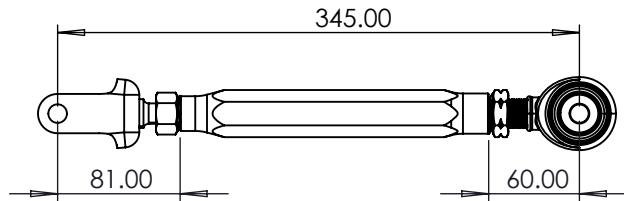

OEM ADJUSTMENT

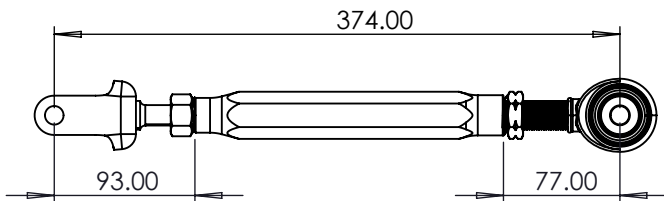

MAX ADJUSTMENT

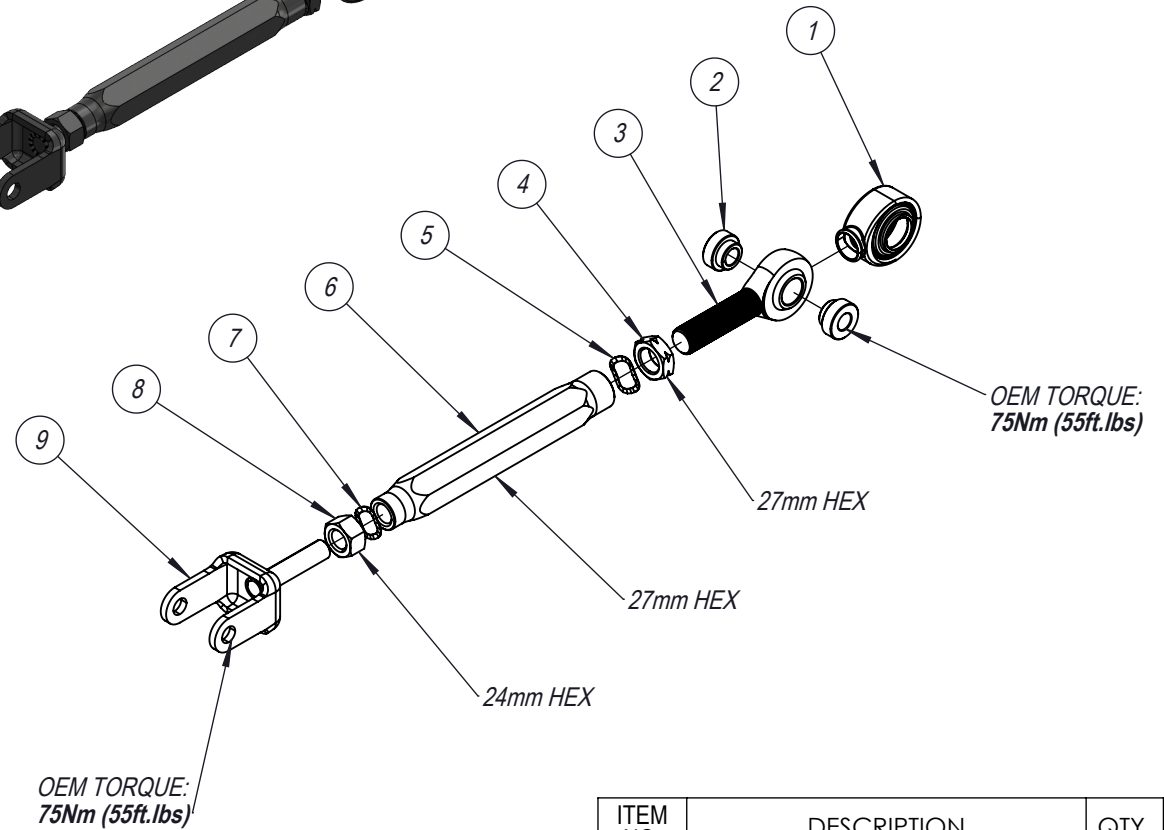

OEM TORQUE:  
75Nm (55ft.lbs)

ITEM NO.	DESCRIPTION	QTY.
1	DUST BOOT	2
2	40MM WIDTH SPACER	4
3	3/4 IN, ROD END, LH	2
4	3/4-16 NUT, LH	2
5	27MM WAVE WASHER	2
6	ARM CENTRE	2
7	24MM WAVE WASHER	2
8	M16 NYLOC NUT	2
9	WELDED CLEVIS ASSEMBLY	2



## CRITICAL!

CHECK FOR ROD END BEARING ALIGNMENT  
AFTER TIGHTENING THE ADJUSTING MECHANISM  
ROD END TO BE PERPENDICULAR TO THE SPACERS

