

**MIN LENGTH - 205MM**

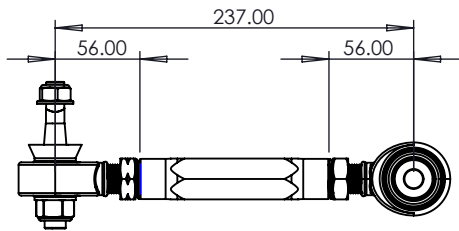

**OEM LENGTH - 237MM**

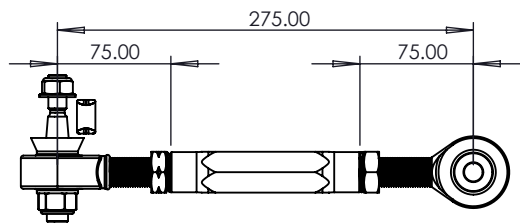

**MAX LENGTH - 275MM**

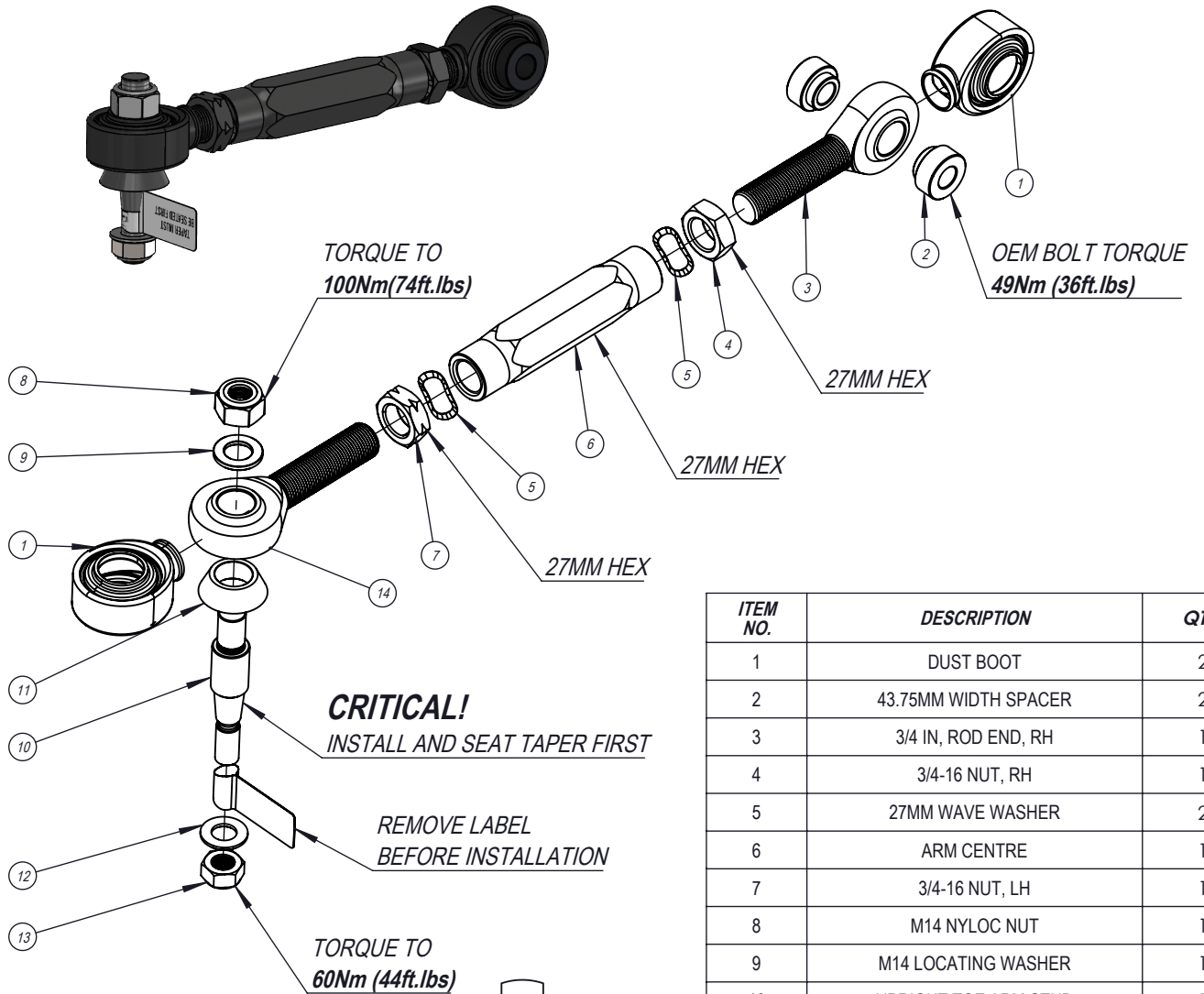

**CRITICAL!**

CHECK FOR ROD END BEARING ALIGNMENT  
AFTER TIGHTENING THE ADJUSTING MECHANISM  
ROD END TO BE PERPENDICULAR TO THE SPACERS

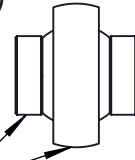

ITEM NO.	DESCRIPTION	QTY.
1	DUST BOOT	2
2	43.75MM WIDTH SPACER	2
3	3/4 IN, ROD END, RH	1
4	3/4-16 NUT, RH	1
5	27MM WAVE WASHER	2
6	ARM CENTRE	1
7	3/4-16 NUT, LH	1
8	M14 NYLOC NUT	1
9	M14 LOCATING WASHER	1
10	UPRIGHT TOE ARM STUD	1
11	ARM SPACER	1
12	M12 WASHER	1
13	M12 NYLOC NUT	1
14	3/4 IN, ROD END, LH	1