

ITEM NO.	DESCRIPTION	QTY.
1	XE10 Knuckle Adapter Body RH	1
2	GK ROD END - PCYML10TS	1
3	XE10 Knuckle Adapter Locator	2
4	DIN961 M14x1.5x90 Grade 10.9	1
5	2.5MM Bump Steer Washer	3
6	2.5MM PCY10TS Spacer	2
7	Thread Adapter M14x1.5 - 110mm	1
8	XE10 Knuckle Adapter Ackerman Adjuster	1
9	Lockstop Weld ASM RH	1
10	ISO 7380 M5x0.8x10	1
11	PCY10TS BOOT	1
12	MINIMUM 15MM THREAD ENGAGEMENT REQUIRED	1
13	DIN 985 M14x1.5 Nylon Locknut	1
14	DIN980 M12x1.25x65 Grade 10.9	2
15	DIN 125 M12X24X2 Washer	2
16	DIN 433 M14X24X2.3 Washer	1
17	21MM WAVE WASHER	1
18	HEAVY HEX JAM NUT 0.381 GRADE 8 2B	1

### 1. REMOVE OEM TIE ROD PICKUP ENSURE TO RETAIN KNUCKLE MOUNTING HOLES

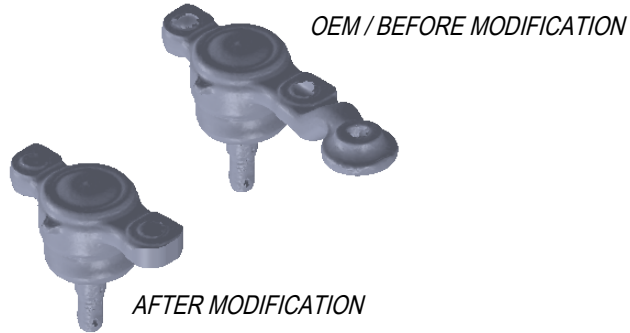

### 3. SET UP LOCK STOP BASED ON SETUP AND CLEARANCE

ENSURE TO CHECK THAT ROD END IS NOT MAKING CONTACT

LOCKSTOP OUTER POSITION - MINIMUM LOCK

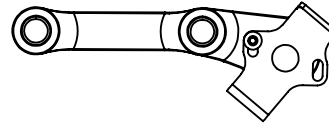

LOCKSTOP INNER POSITION - MAXIMUM LOCK

\*REQUIRES SWAY BAR END LINK REMOVAL FOR CLEARANCE

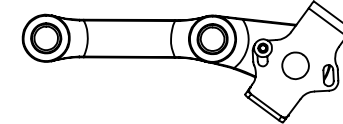

SWITCH L/H AND R/H LOCKSTOPS - FOR +25MM LCAs

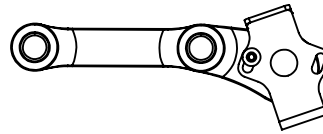

### 2. CHOOSE BETWEEN ACKERMANN SETTINGS

**OUTSIDE** - PRO ACKERMANN, MORE PARALLEL STEERING + MORE LOCK

**INSIDE** - LESS ACKERMANN, CLOSER TO OEM + LESS LOCK

**WHEN CHANGING ACKERMANN** - LOOSEN TIE ROD LOCK NUT AND TURN TIE ROD 4 FULL TURNS (6mm) TO RETAIN TOE SETTING

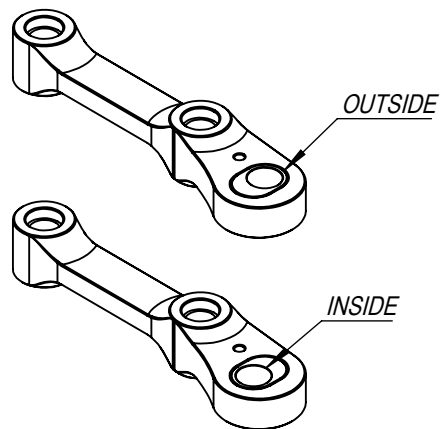

### 4. SET UP BUMP STEER SPACERS, THESE SPACERS CAN BE MOVED ABOVE THE BEARING TO REDUCE BUMP STEER EFFECTS

OEM HEIGHT - SPACERS BELOW

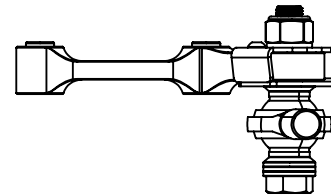

-25MM HEIGHT - ONE SPACER ABOVE

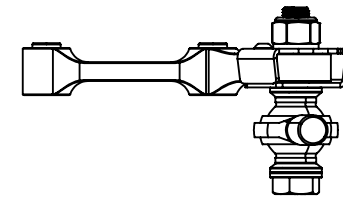

-50MM HEIGHT - TWO SPACERS ABOVE

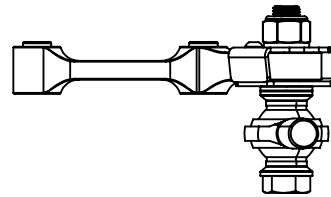

-75MM HEIGHT - THREE SPACERS ABOVE

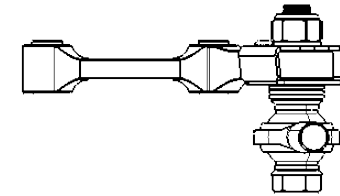

## 5. INSTALL HARDWARE TO ADAPTER

TIGHTEN AND TORQUE TO 10Nm (7.5ft.lbs)

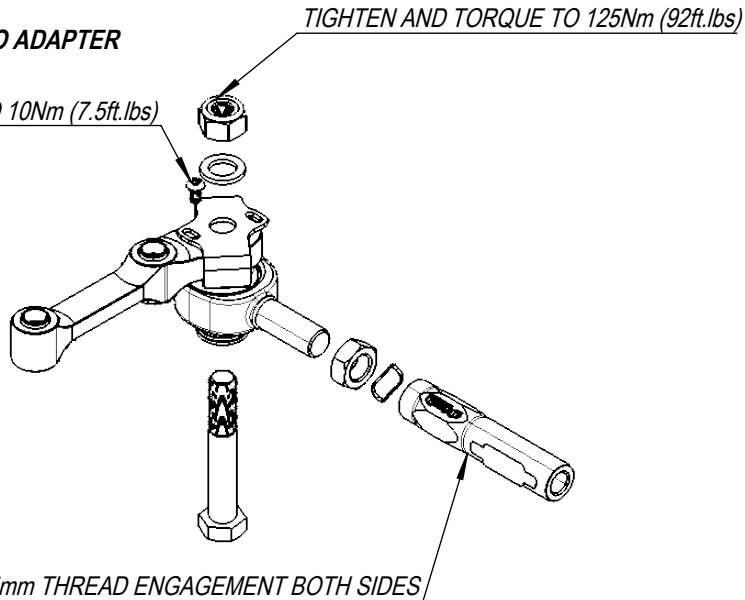

## 6. INSTALL ADAPTER TO OEM KNUCKLE

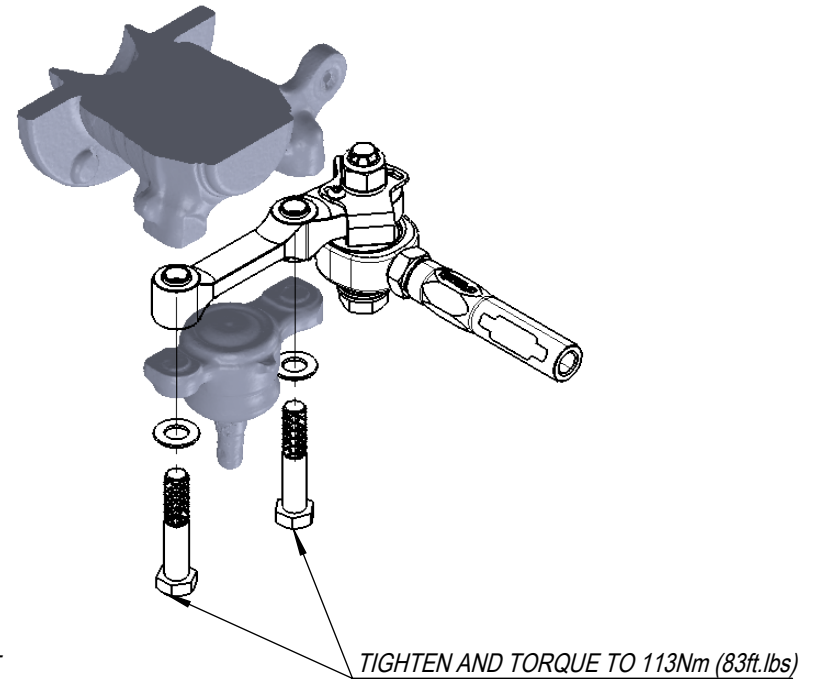

\*\* OEM DUST SHIELD MUST BE REMOVED OR TRIMMED TO SUIT  
REMOVE BY CUTTING ALONG LINES BELOW

