

MIN LENGTH - 415MM

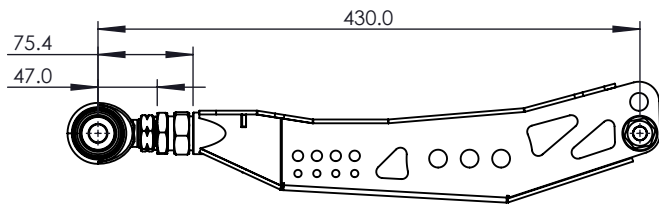

OEM LENGTH - 430MM

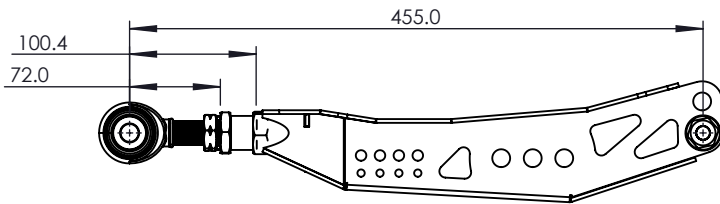

MAX LENGTH - 455MM

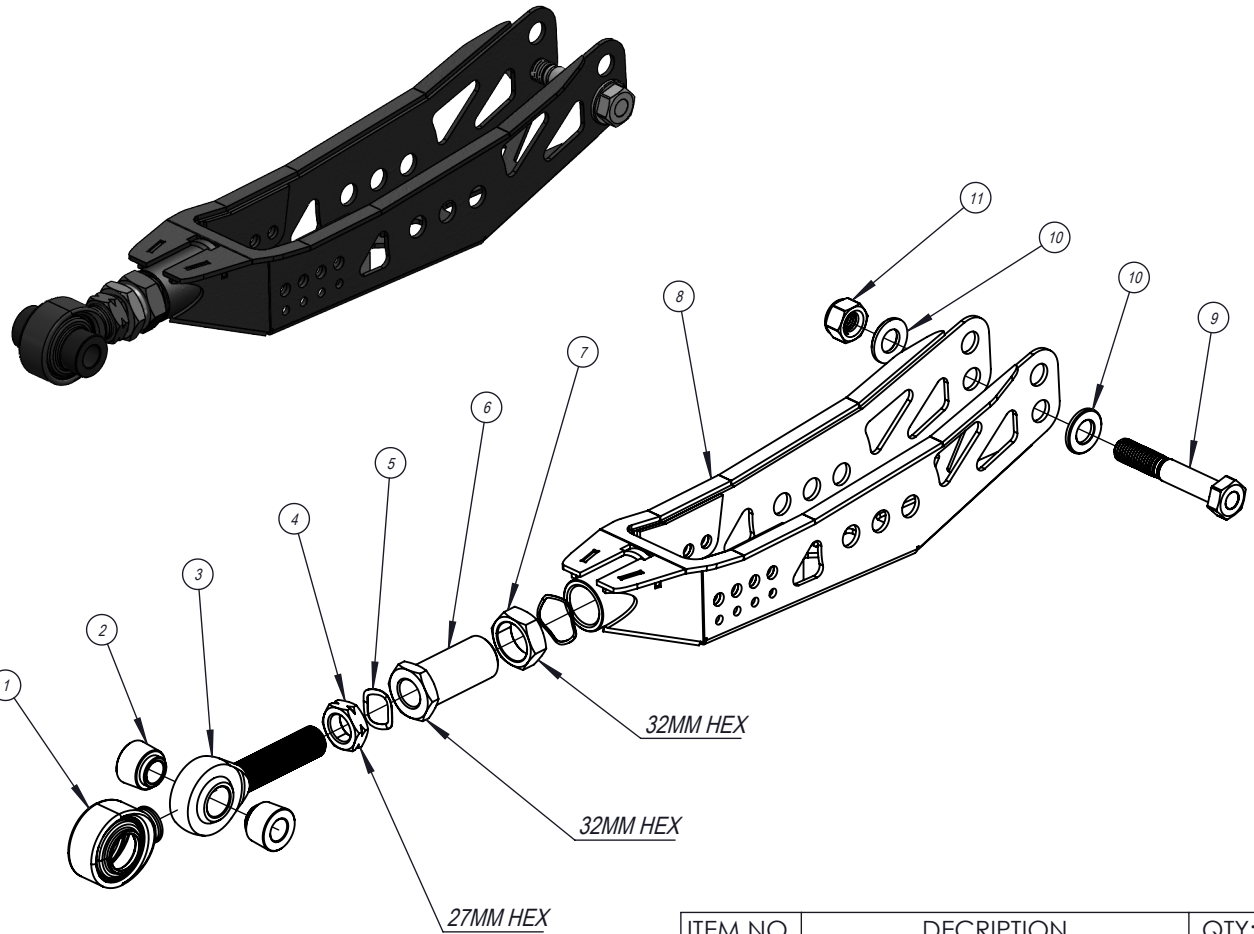

ITEM NO.	DESCRIPTION	QTY:
1	DUST BOOT	2
2	54MM WIDTH SPACER	4
3	3/4 IN, ROD END, LH	2
4	3/4-16 NUT, LH	2
5	27MM WAVE WASHER	2
6	DOUBLE ADJUSTER SLEEVE	2
7	M27 NUT	2
8	WELDED ARM BODY	2
9	M14 X 80 BOLT	2
10	M14 WASHER	4
11	M14 NYLOC LOCKNUT	2
12		1

CRITICAL!

CHECK FOR ROD END BEARING ALIGNMENT AFTER TIGHTENING THE ADJUSTING MECHANISM
ROD END TO BE PERPENDICULAR TO THE SPACERS

