

V413-PROX V414-PROX

NOTE! S14 S1 comes OEM with a spindle hub washer
S14 S2/S15 does not use a spindle hub washer

The GKTECH knuckles have been designed not to use a spindle hub washer

As such, if you have an S14 S1 the spindle hub washer is to be discarded

WHEEL ALIGNMENT RECOMMENDATIONS

These specs are to be used as a starting point and then adjusted as required

These knuckles are designed for lower caster values and have inbuilt caster trail
Running OEM caster can give poor steering feel

Camber: -3 degrees

Caster: 4 degrees

Total Toe: 2mm OUT

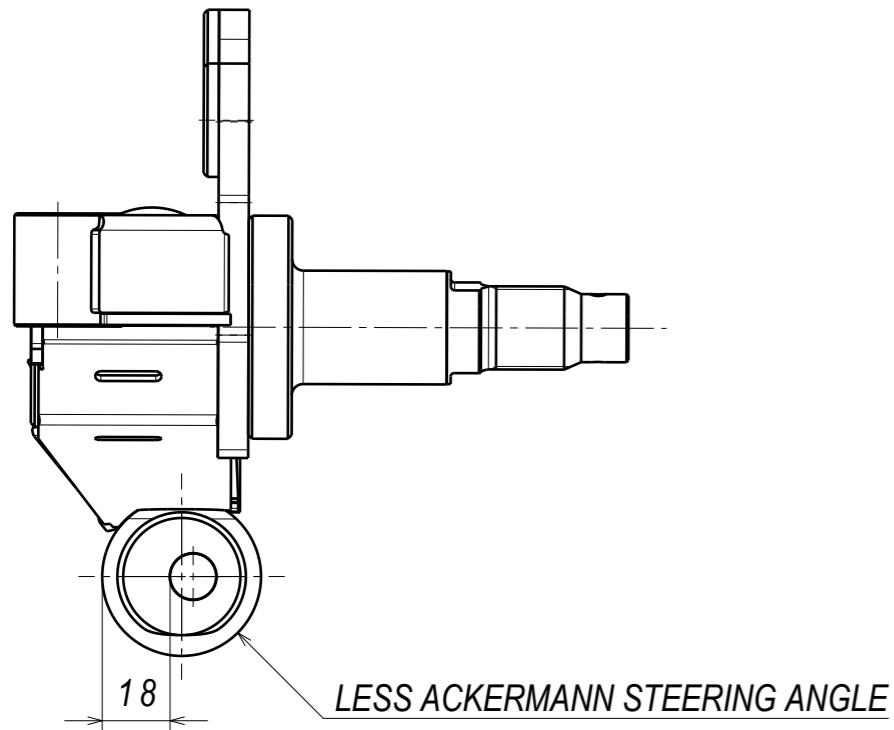
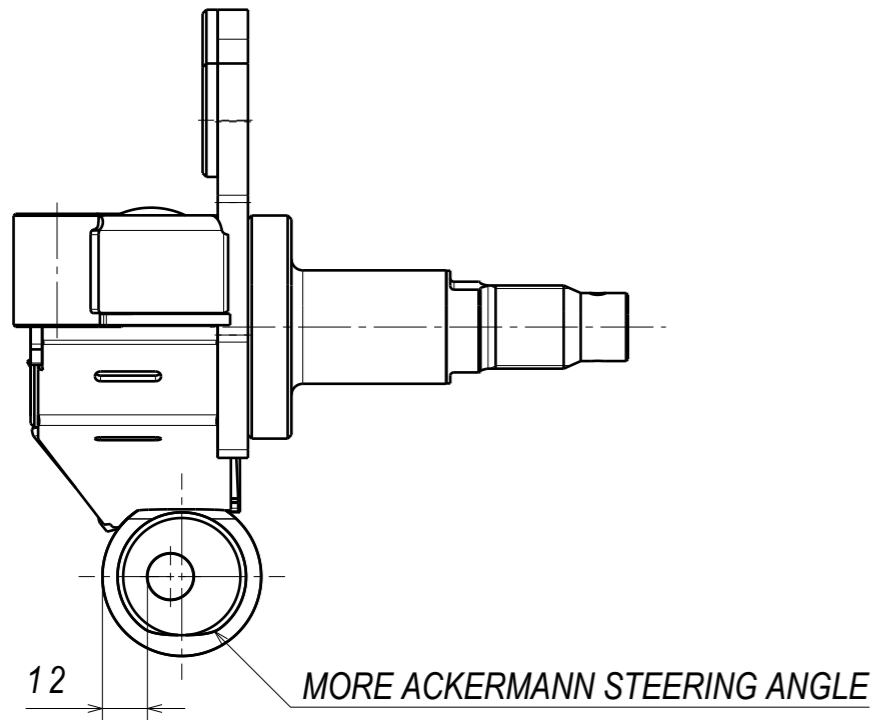

S13 SPINDLE : TIGHEN NUT TO 135 Nm (100 lbs-ft)
S14 SPINDLE: TIGHTEN NUT TO 150 Nm (110 lbs-ft)

S13 SPINDLE : TIGHEN NUT TO 190 Nm (140 lbs-ft)
S14 SPINDLE: TIGHTEN NUT TO 240 Nm (177 lbs-ft)

TIGHTEN NUT TO 70 Nm (50 lbs-ft)

TOP ACKERMANN INSERT

TIGHEN TO 85 Nm (62 lbs-ft)
(OEM CALIPERS)

TIGHTEN NUT TO 110 Nm (82 lbs-ft)

STEERING KNUCKLE

BOTTOM ACKERMANN INSERT

