

MINIMUM LENGTH - 189mm

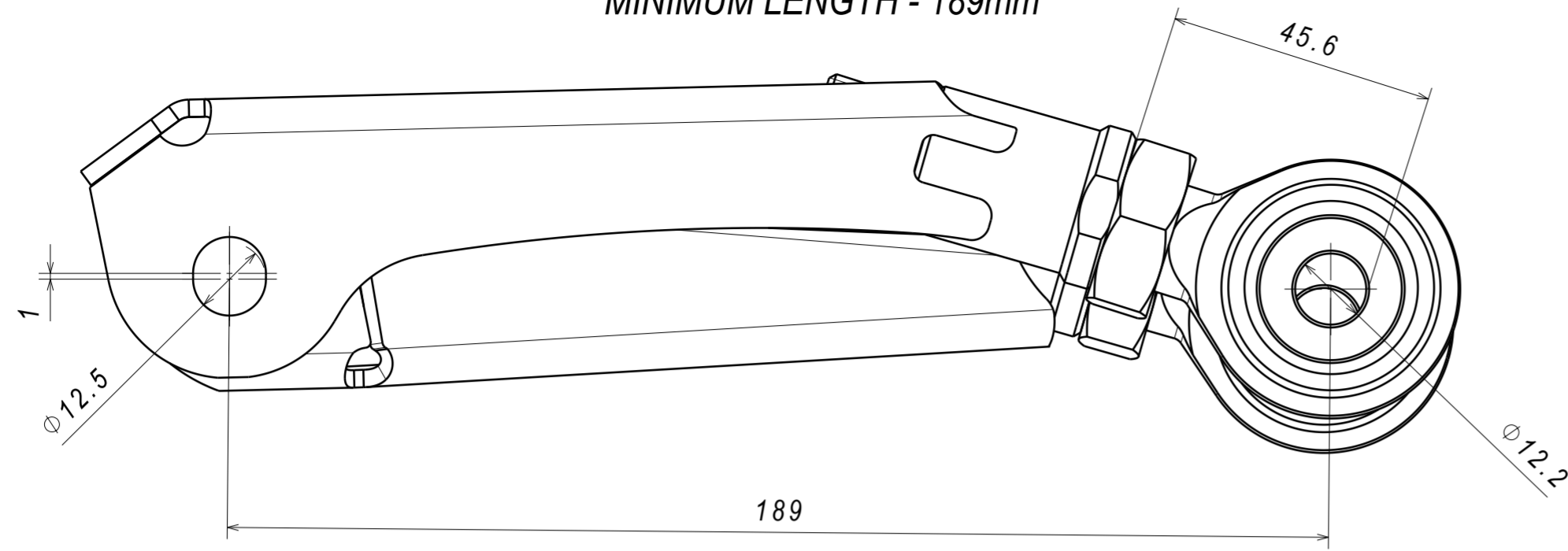

OEM LENGTH - 191mm

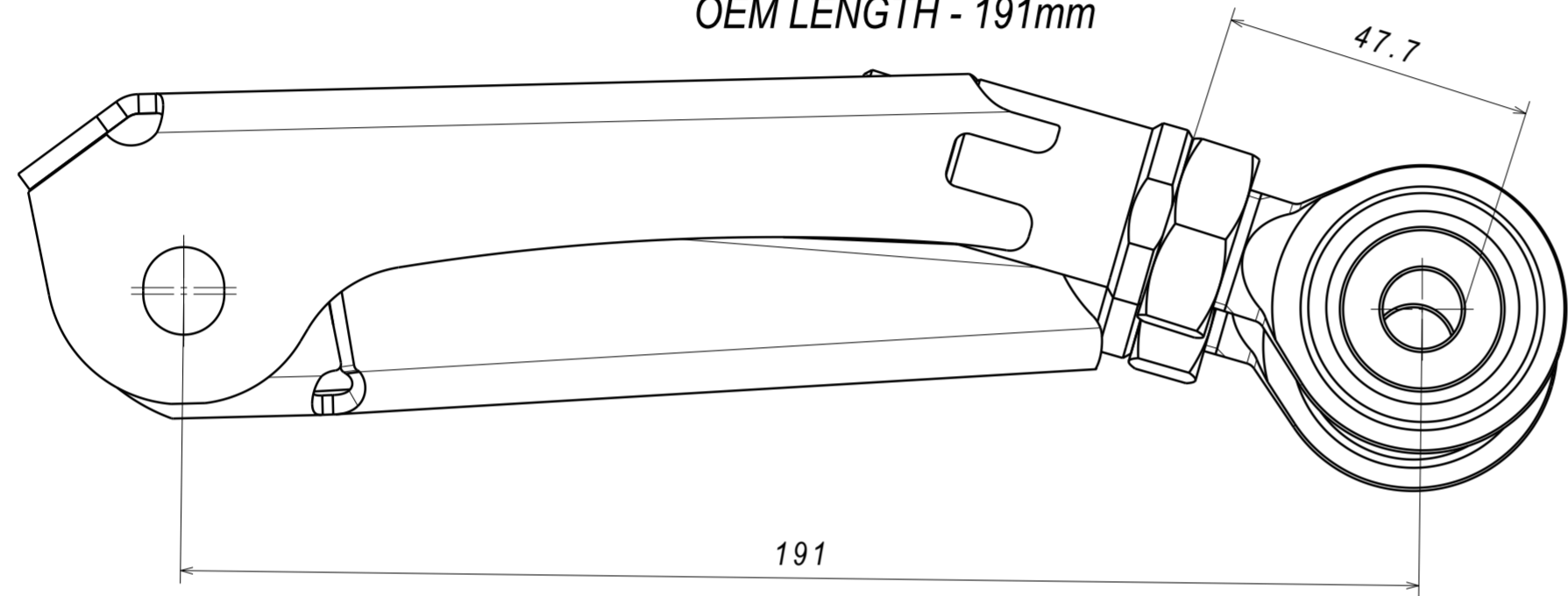

MAXIMUM SAFE LENGTH - 220mm

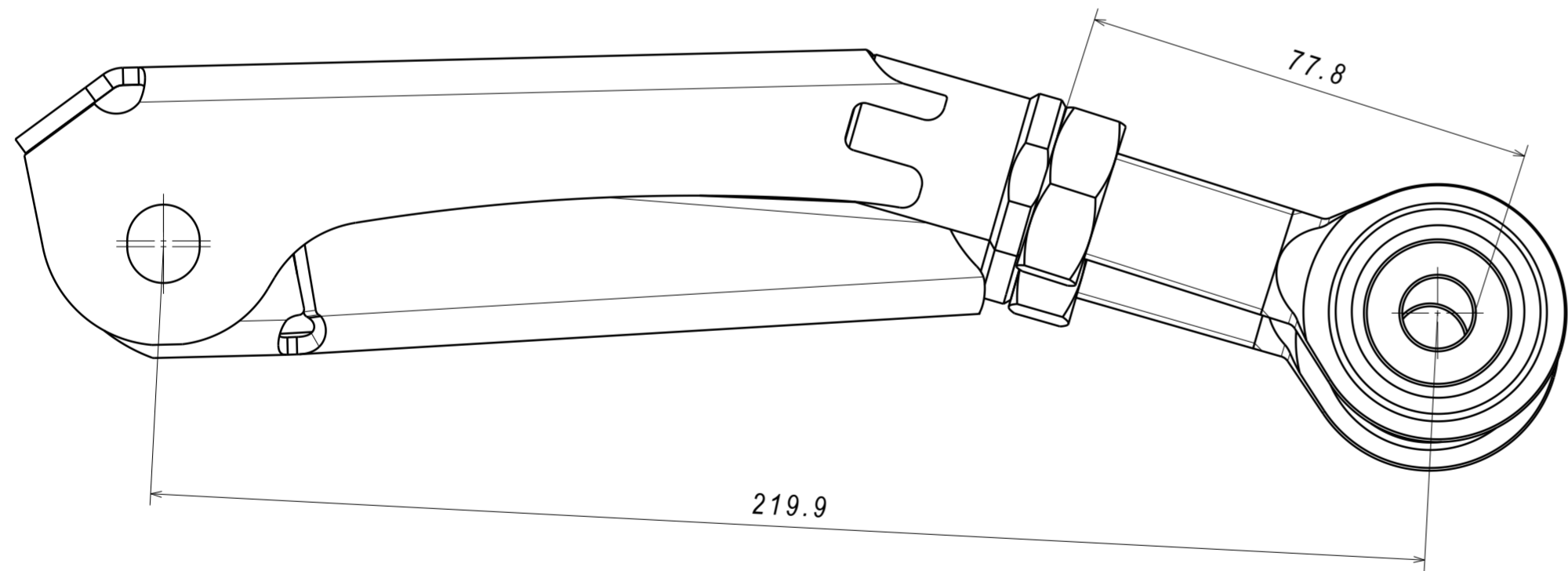

EXPLODED VIEW OF RIGHT HAND SIDE UPPER ARM ASSEMBLY

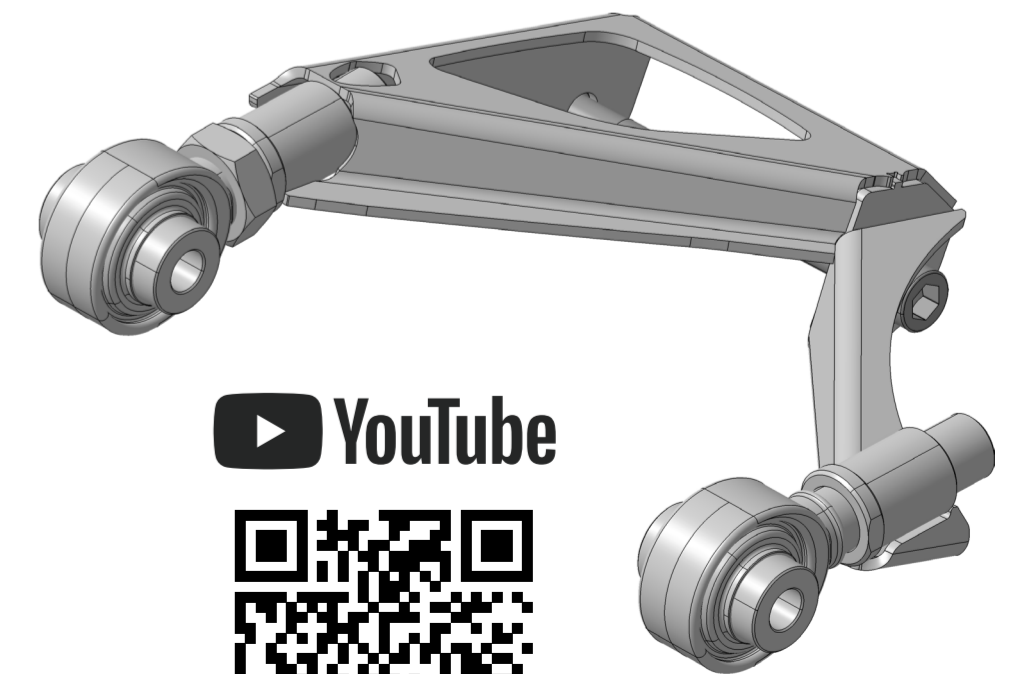
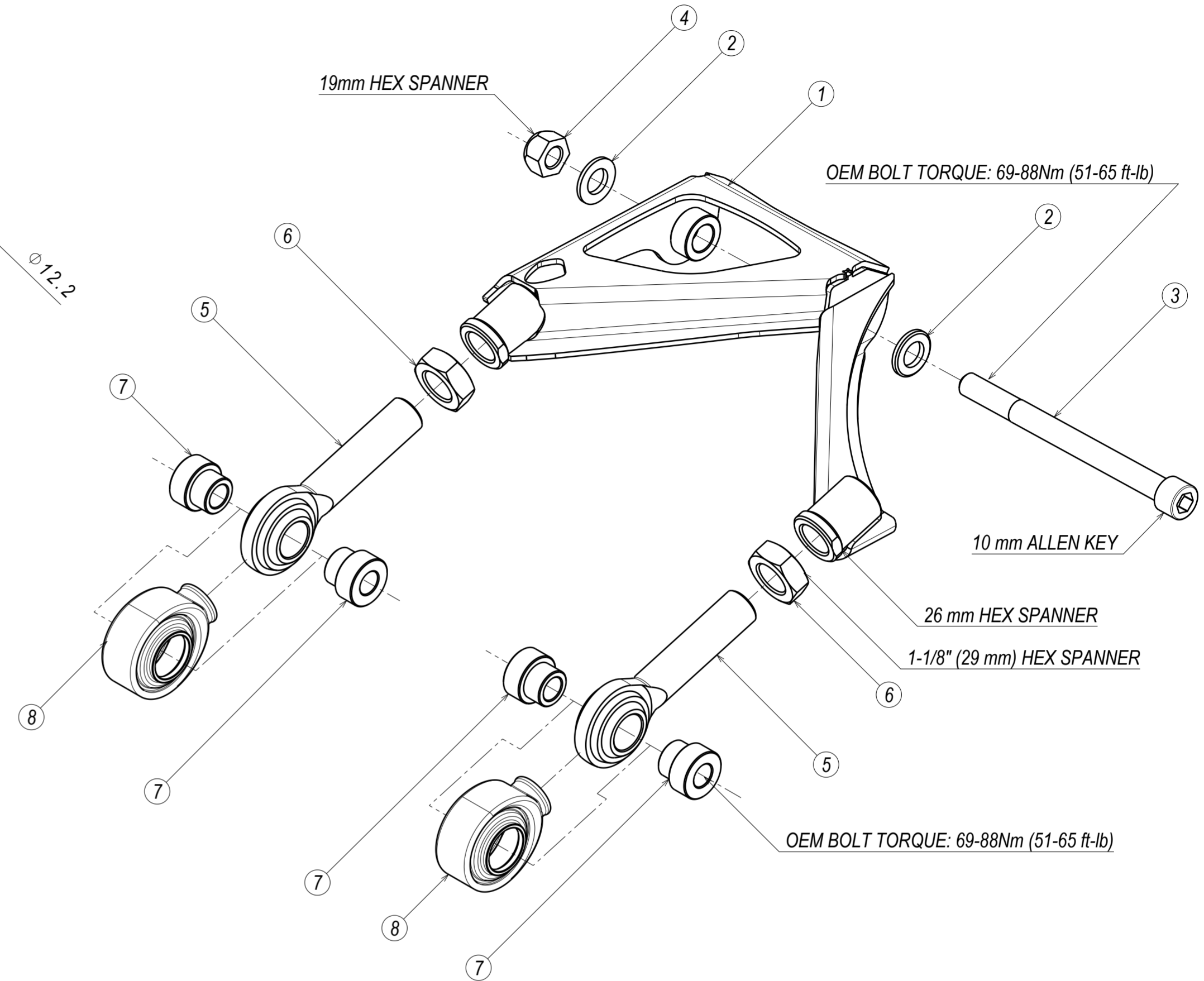

YouTube

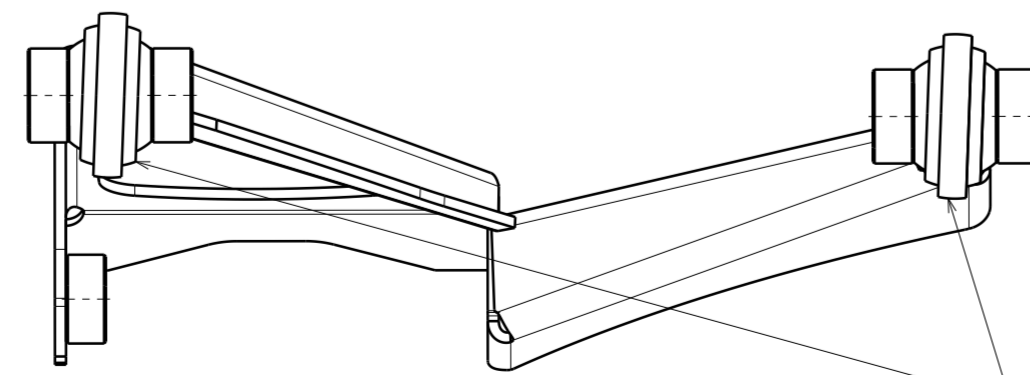

CHECK FOR ROD END BEARING ALIGNMENT
AFTER TIGHTENING THE ADJUSTING MECHANISM
IT MUST BE PARALLEL TO THE BODY OF THE ROD END

8	ROD END COVER	2
7	SPACER - PCML12T 12ID 45W	4
6	JAM NUT 3/4-16 UNF 3B LH (HEIGHT 10,7mm)	2
5	ROD END PCML12T-E	2
4	NYLON LOCKING NUT DIN 985-8 M12x1.75	1
3	ISO 4762 SCREW M12x140	1
2	ISO 7091 WASHER 12x24	2
1	R33 UPPER ARM BODY	1
ITEM NO.	DESCRIPTION	QTY