

# GTR1-CSTR

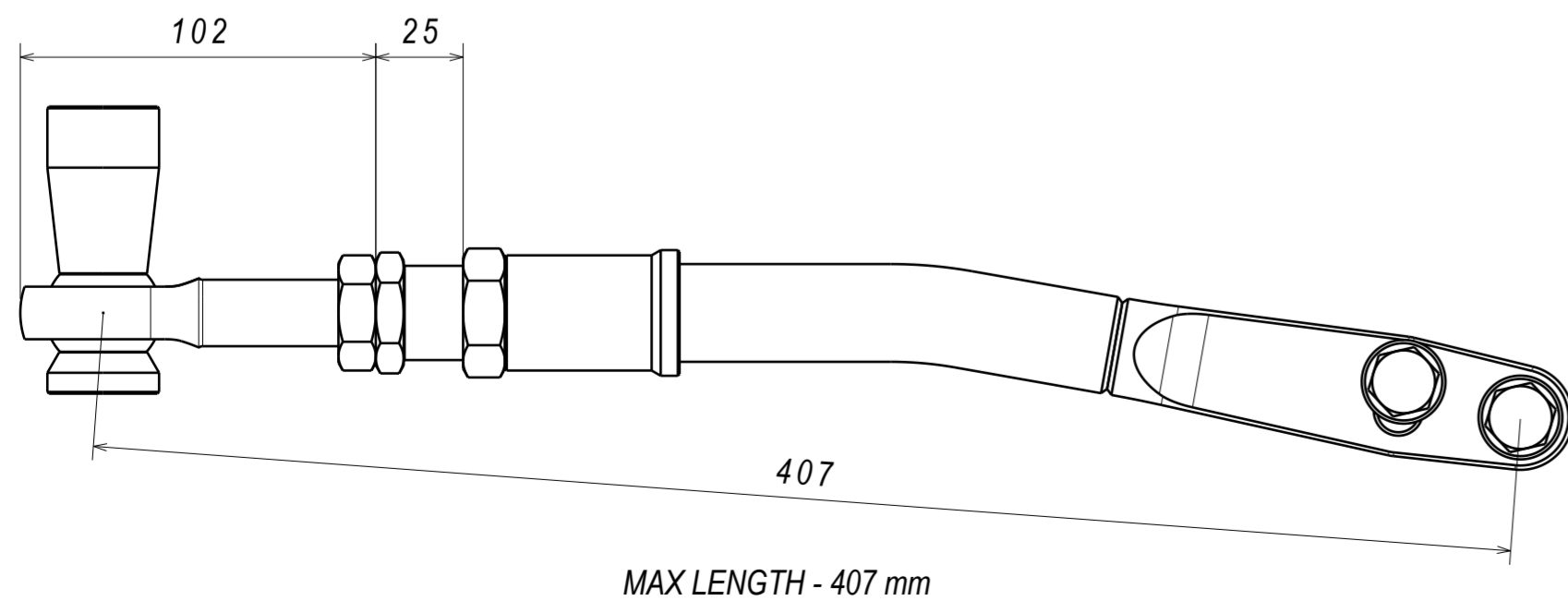

## CRITICAL!

CHECK FOR ROD END BEARING ALIGNMENT  
AFTER TIGHTENING THE ADJUSTING MECHANISM  
ROD END TO BE PERPENDICULAR TO THE SPACERS

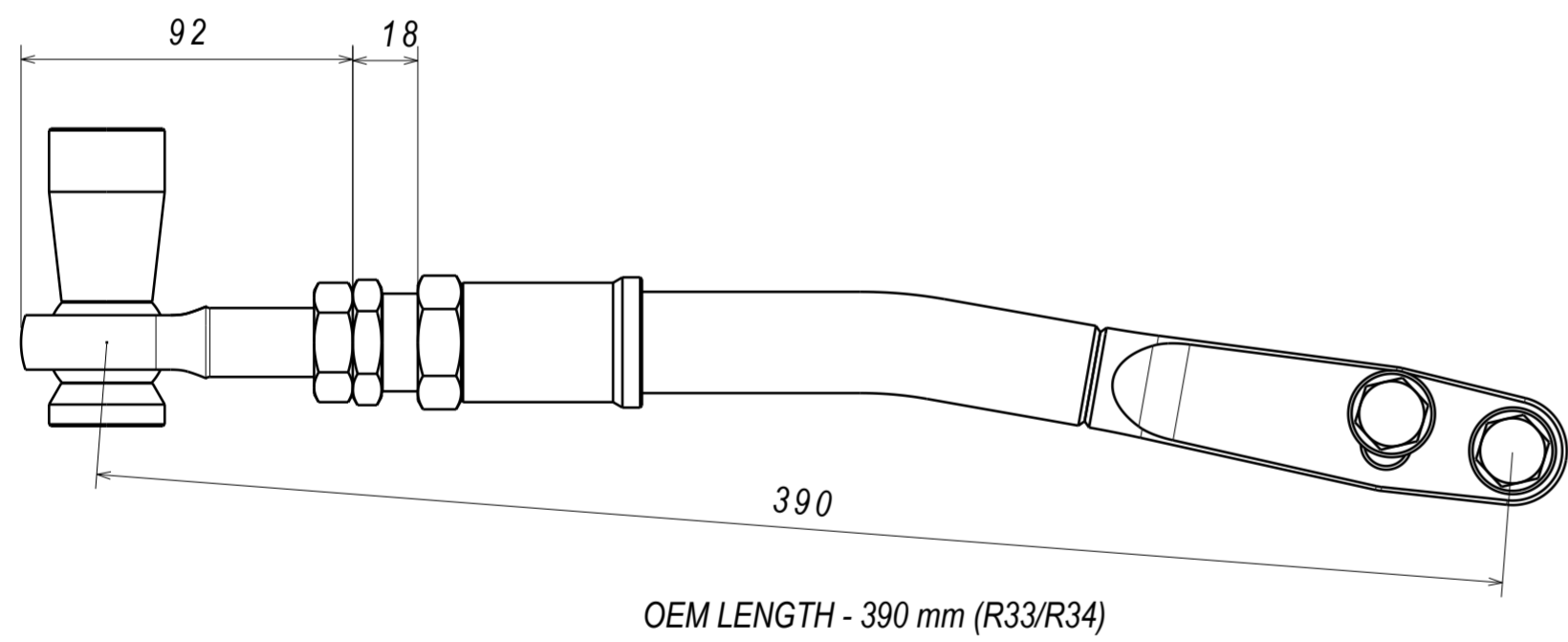
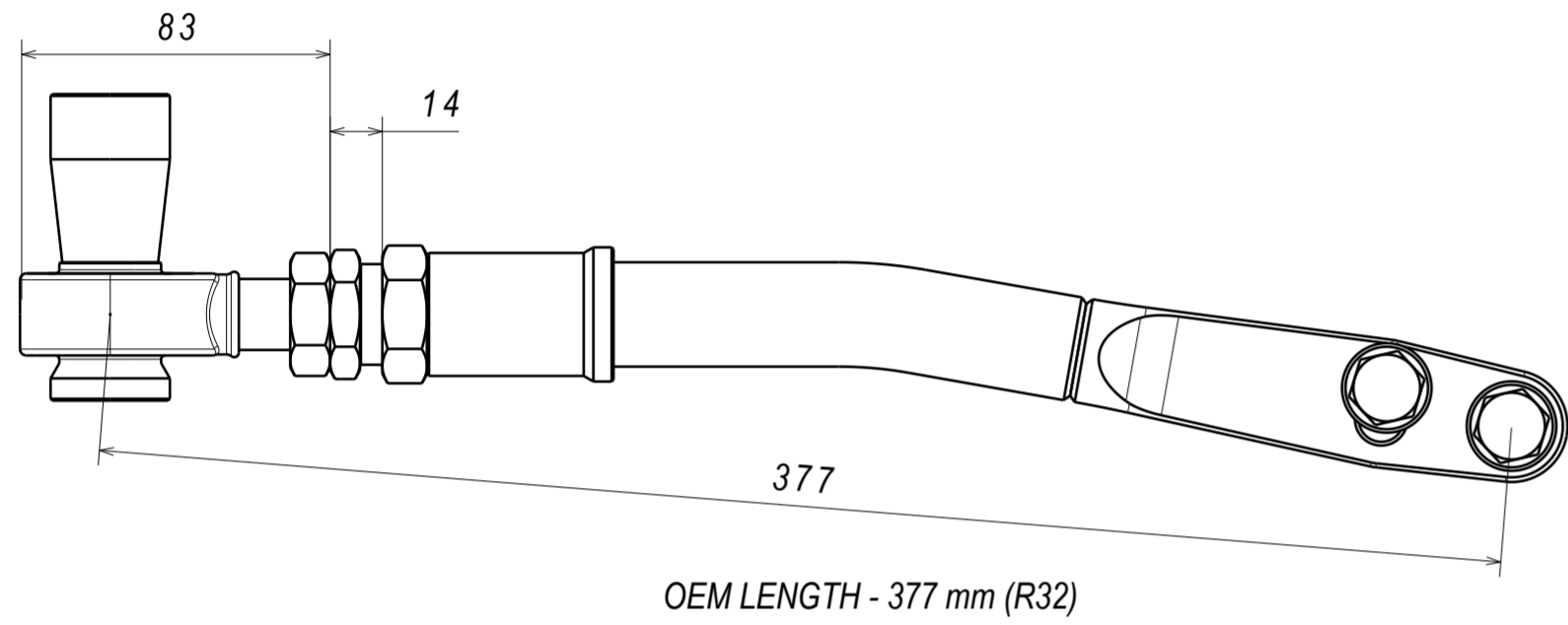
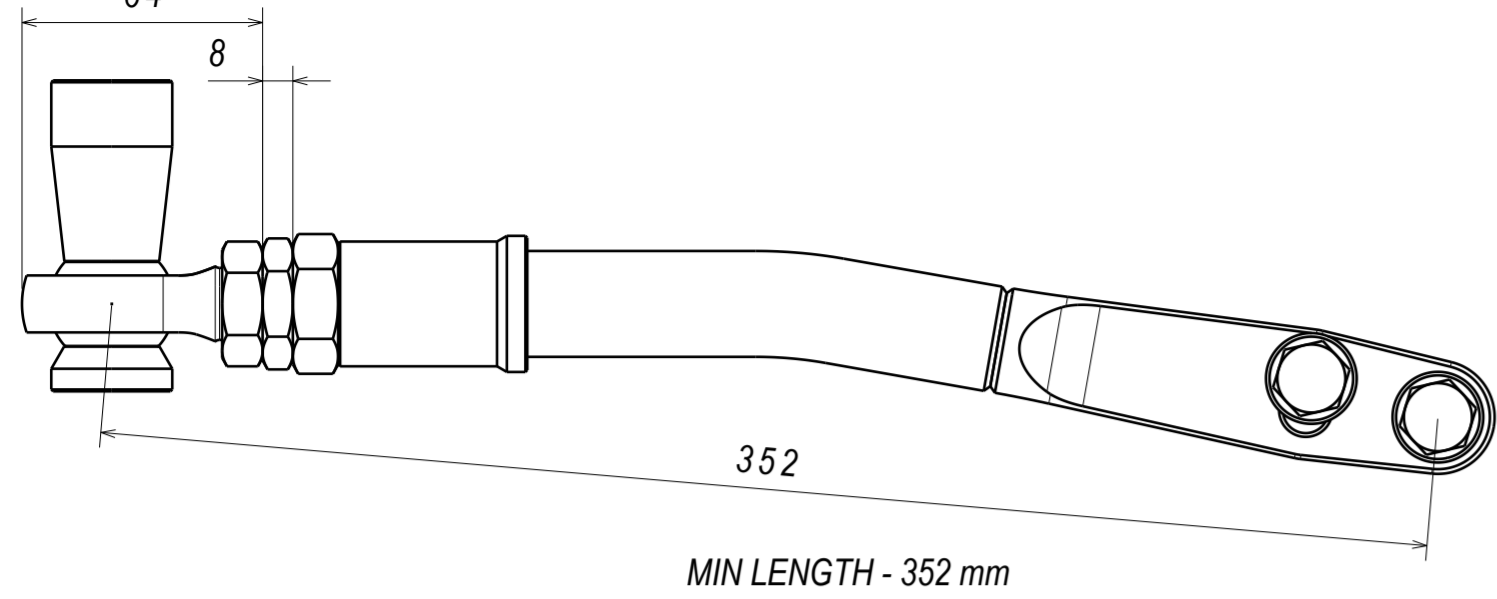
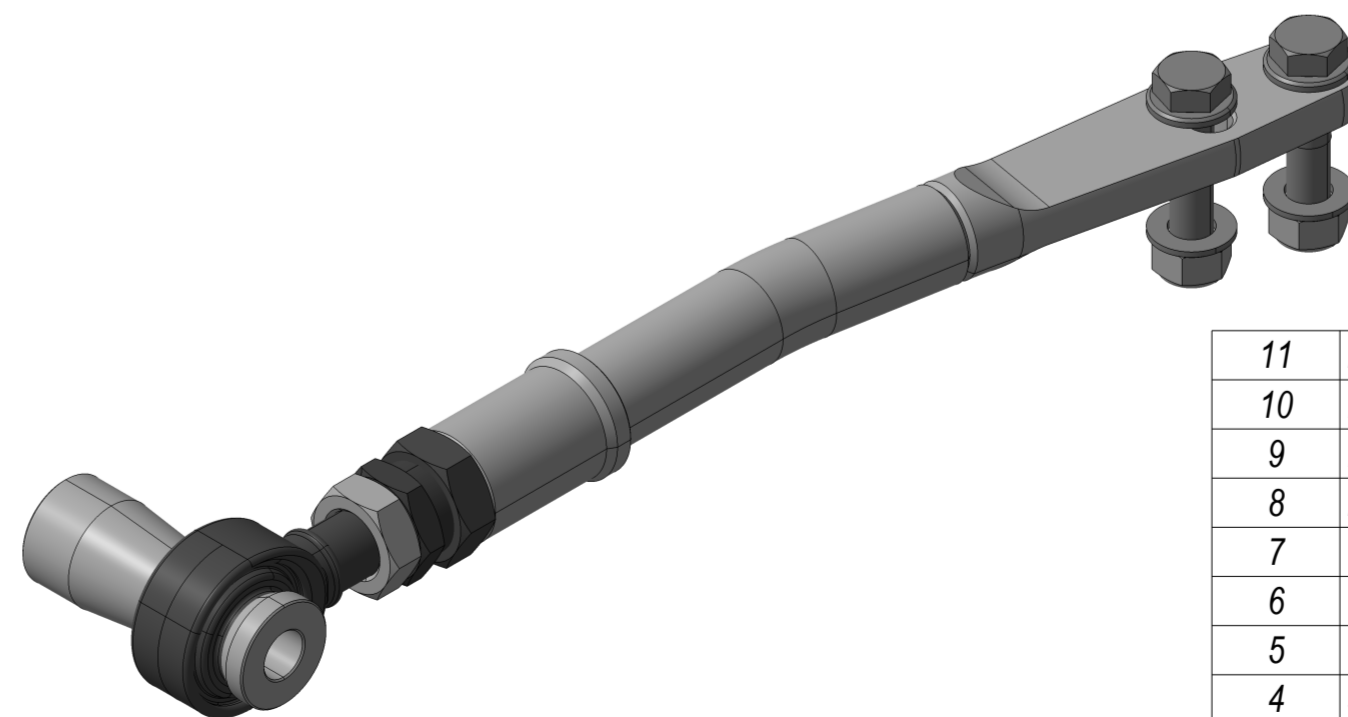
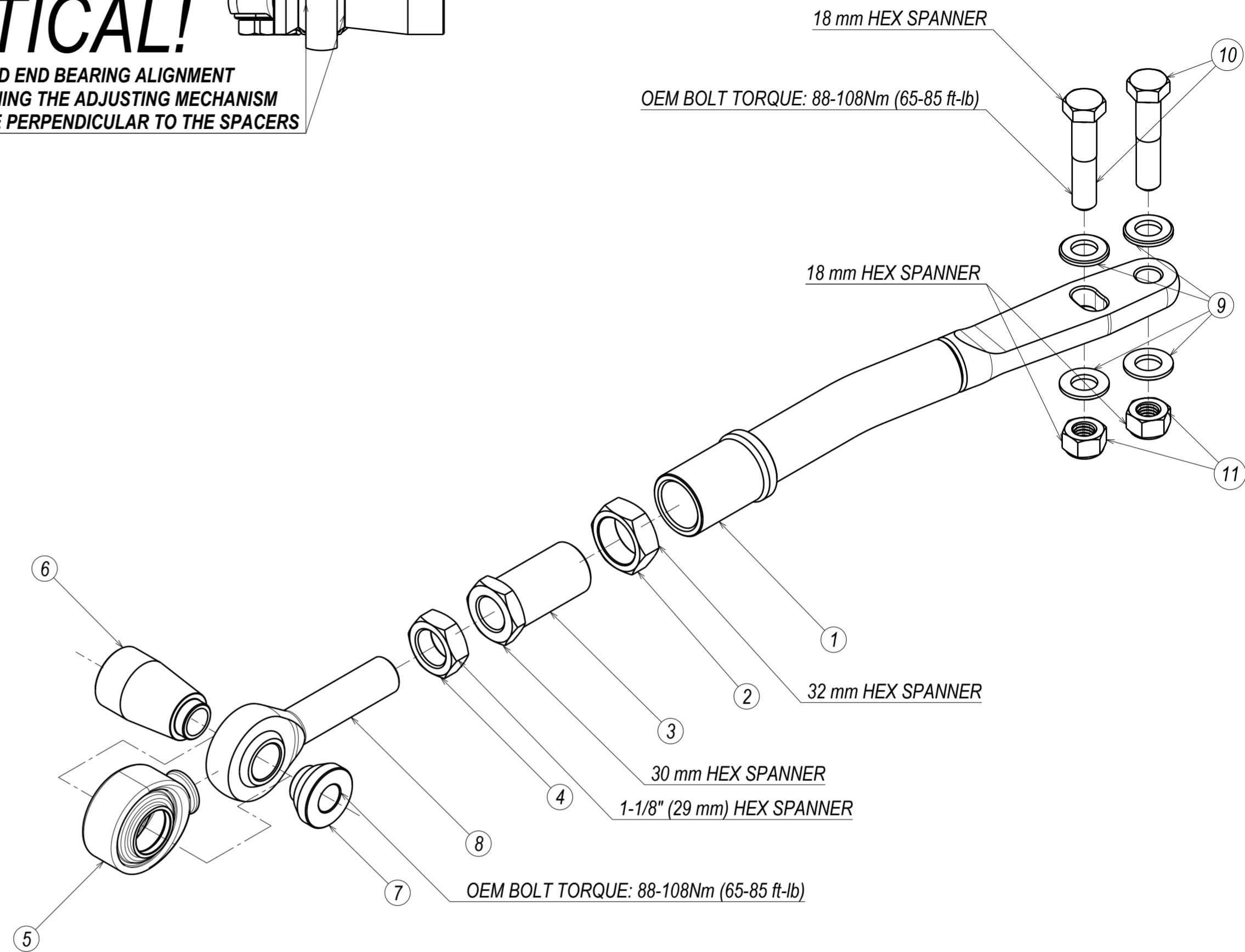
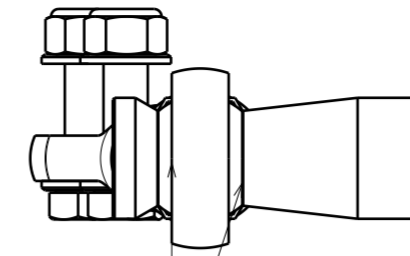

11	NYLOC LOCKING NUT DIN 985-8 M12x1.5	2
10	ISO 4017 SCREW M12x45 STEEL HEXAGON HEAD	2
9	ISO 7089 WASHER 12x24 GRADE A ZINC	4
8	ROD END PCML12T-E LEFT HAND THREAD	1
7	TENSION ROD SPACER INSIDE	1
6	GTR TENSION ROD SPACER OUTSIDE	1
5	QA1 PCML12T BOOT REV2	1
4	3/4-16 ASTM A563 GRADE A ZINC STEEL JAM NUT LH THREAD	1
3	FLCA VERNIER SLEEVE	1
2	FLCA M27 JAM NUT	1
1	STRAIGHT TENSION ROD WELDING ASM GTR	1
PC NO	COMPONENT NAME	QTY