

MIN ADJUSTMENT

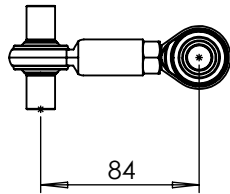

OEM/MAX ADJUSTMENT

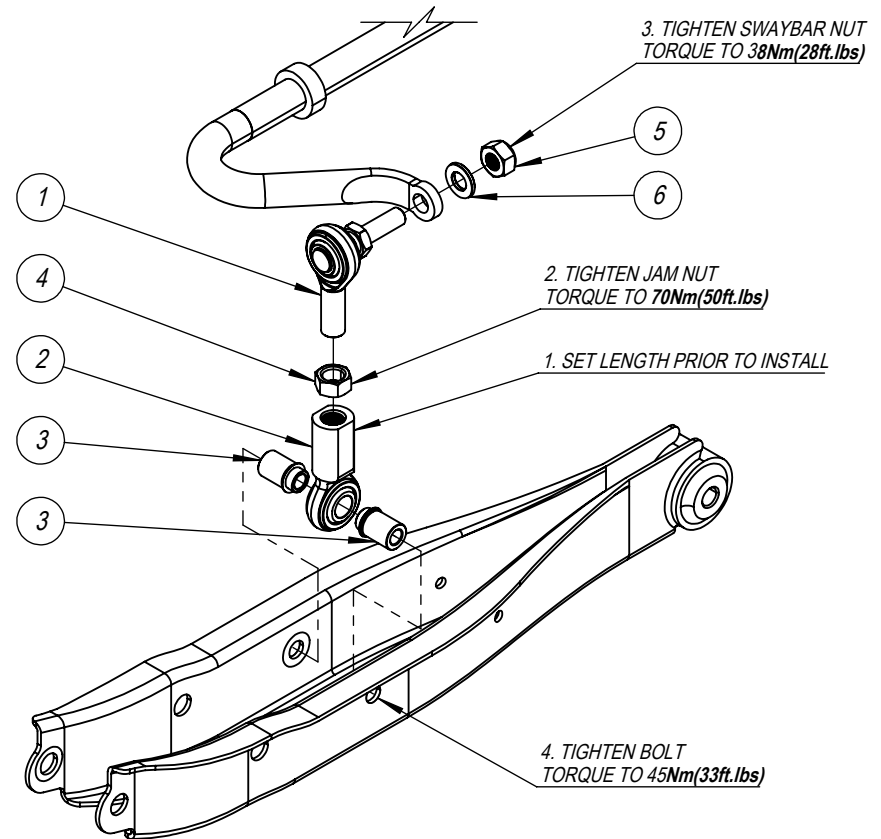
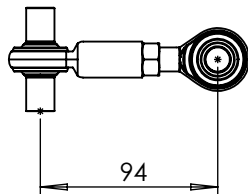

ITEM NO.	DESCRIPTION	QTY.
1	ACMR8TS-10-M10x1.25x30	1
2	ACF8TS Bearing	1
3	ACF8TS Spacer 8 x 55	2
4	NUT 1/2-20 R/H UNF	1
5	M10x1.25 Nylon Locknut	1
6	M10 Washer	1