

# GT86-LHIL

1. IN THE DRIVER FOOTWELL, DETACH AND FOLD DOWN THE CARPET TO REVEAL THE FIREWALL.
2. MARK AND USE A STEPPER DRILL TO MAKE A 30MM DIAMETER HOLE DIRECTLY BELOW THE STEERING COLUMN. SEE DIAGRAM A.
3. INSTALL SUPPLIED RUBBER GROMMET IN THE HOLE TO PROTECT BRAKE LINES.
4. ENSURE THAT THE HANDBRAKE ASSEMBLY AND MASTER CYLINDER IS INSTALLED IN THE VEHICLE.
5. ROUTE THE BRAKE LINES THROUGH THE HOLE. INSTALL LINES FIRST TO THE HYDRO MASTER CYLINDER, THEN TO THE OEM MASTER CYLINDER AND ABS DELETE BLOCK. TIGHTEN ALL FITTINGS.
6. USE SUPPLIED P-CLIPS SECURE LINES FIRMLY IN THE FOOTWELL SO THEY CANNOT AFFECT PEDAL OPERATION.
7. ONCE INSTALLED, BLEED THE BRAKES AS NORMAL WITH THE FOOT BRAKE.

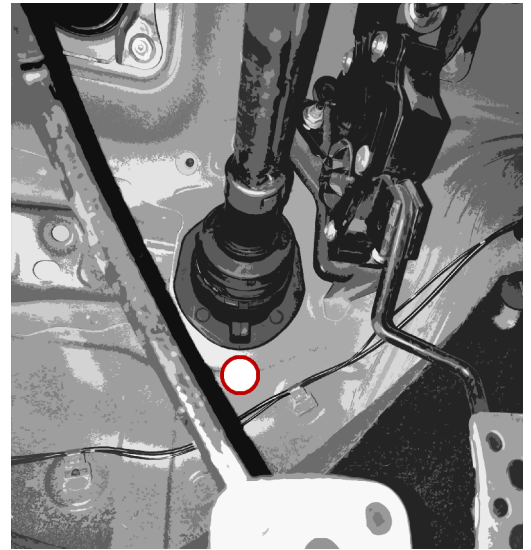

**DIAGRAM A**

*ANGLE BANJO TOWARDS REAR AND DOWN AND INSTALL IT IN A LOOSE LOOP.*

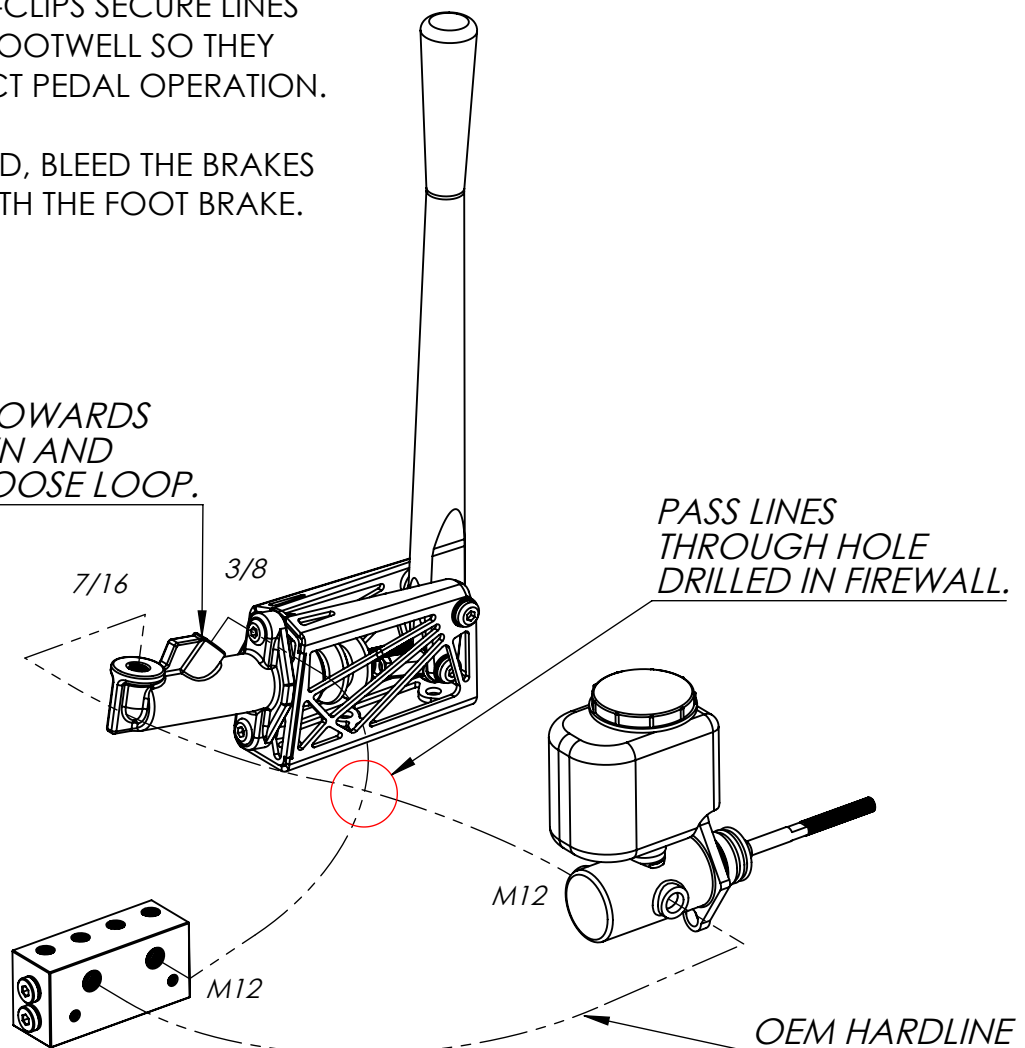

**DIAGRAM B**