

F8XX-DIFR

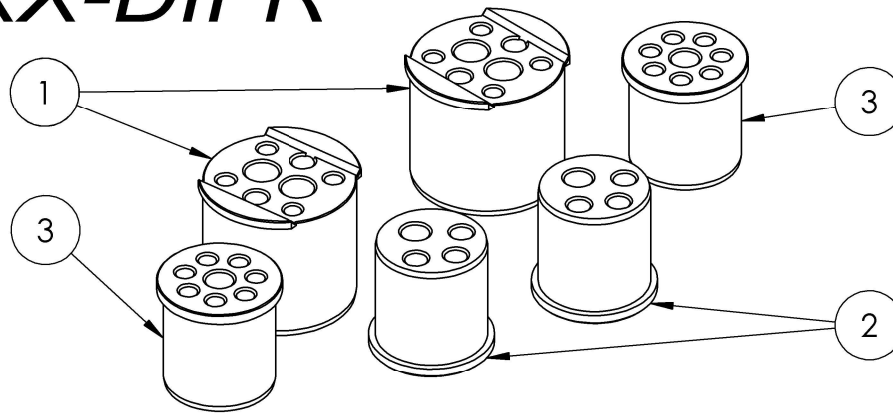

DIAGRAM A

1. REMOVE THE DIFF FROM THE REAR SUBFRAME.
2. PRESS OUT THE OEM REAR BUSH. CLEAN AND GREASE THE OEM AND ADDITIONAL MOUNTING HOLES.
3. USE A PRESS TO REMOVE THE OEM FRONT DIFF BUSHES FROM THE CRADLE. PRESS ON THE INNER SECTION OF THE BUSH AND MAKE SURE TO ADEQUATELY SUPPORT THE CRADLE. IF NOT SUPPORTED CORRECTLY, CRADLE WILL CRACK!
4. USE A RUBBER Mallet (OR HAMMER AND WOOD) TO INSTALL THE REAR BUSHES FROM INSIDE OF THE SUBFRAME.

AGAIN, USE THE PRESS TO INSTALL THE SOLID FRONT DIFF BUSHES, TAKING CARE WITH BUSH ORIENTATION (DIAGRAM B/C/D) AND SUPPORTING THE CRADLE THROUGHOUT.

CRITICAL!!! BUSH INSTALL ORIENTATION IS CRITICAL, SEE DIAGRAMS B,C AND D.

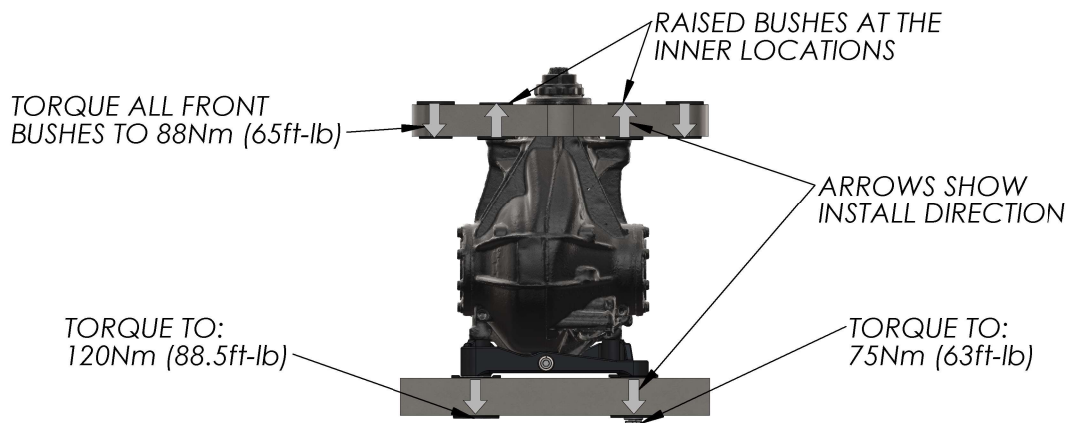

DIAGRAM B

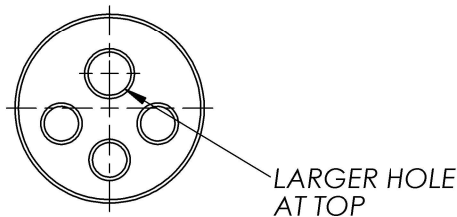

DIAGRAM C

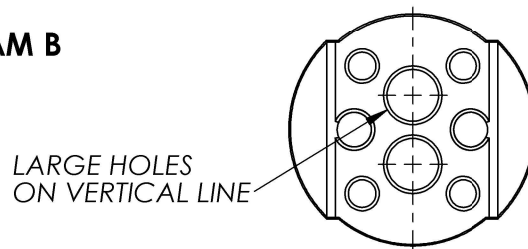

DIAGRAM D

ITEM NO.	DESCRIPTION	QTY.
1	F8X REAR RAISE DIFF BUSH	2
2	F8X FRONT RAISE DIFF BUSH	2
3	F8X FRONT DIFF BUSH	2

F8XX-DIFR

5. THE RAISED DIFF REQUIRES A SMALL AMOUNT OF GRINDING FOR CLEARANCE TO THE FRONT CRADLE AND TO THE SUBFRAME. THE DIFF CASTING MUST BE GROUND IN 2 LOCATIONS.

AT THE FRONT OF THE DIFF AT THE TOP THERE IS A MACHINED FLAT SECTION WHICH THEN TRANSITIONS TO A RAISED NUB. THIS NUB NEEDS TO BE GROUND FLAT TO MATCH THE MACHINED SECTION.

ADDITIONALLY, THERE IS A CASTING JOIN RIDGELINE THAT RUNS OVER THE TOP OF THE DIFF. THIS RIDGE NEEDS TO BE GROUND DOWN IN AN AREA JUST REAR OF WHERE THE TOP OF THE DIFF STARTS TO RISE UP.

THESE CAN BE SEEN IN DETAIL F:

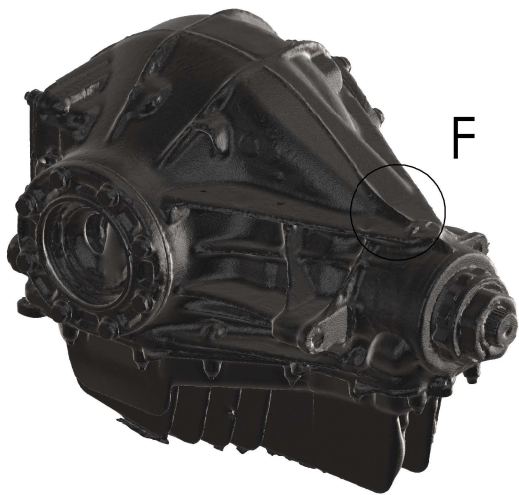

DIAGRAM E



DETAIL F

6. PAINT RAW METAL TO INHIBIT RUST AND CORROSION.
7. TEST FIT THE DIFF INTO THE SUBFRAME. CHECK FOR CLEARANCE BETWEEN THE DIFF CASTING AND THE CRADLE AND SUBFRAME. GRIND ADDITIONAL AS REQUIRED.
8. **CRITICAL!!!** DUE TO ALL BUSHES BEING SOLID, START ALL BOLTS A FEW THREADS FIRST, THEN HAND TIGHTEN THE REMAINDER.

TORQUE ALL BOLTS TO THE SPECIFIED VALUES IN DIAGRAM B.