

FOR SOME S13 MODELS SEE NOTE BELOW FOR THIS MOUNT BRACKET

OEM BOLT TORQUE: 3.2-4.2 Nm (2.4-3.1 ft-lb)

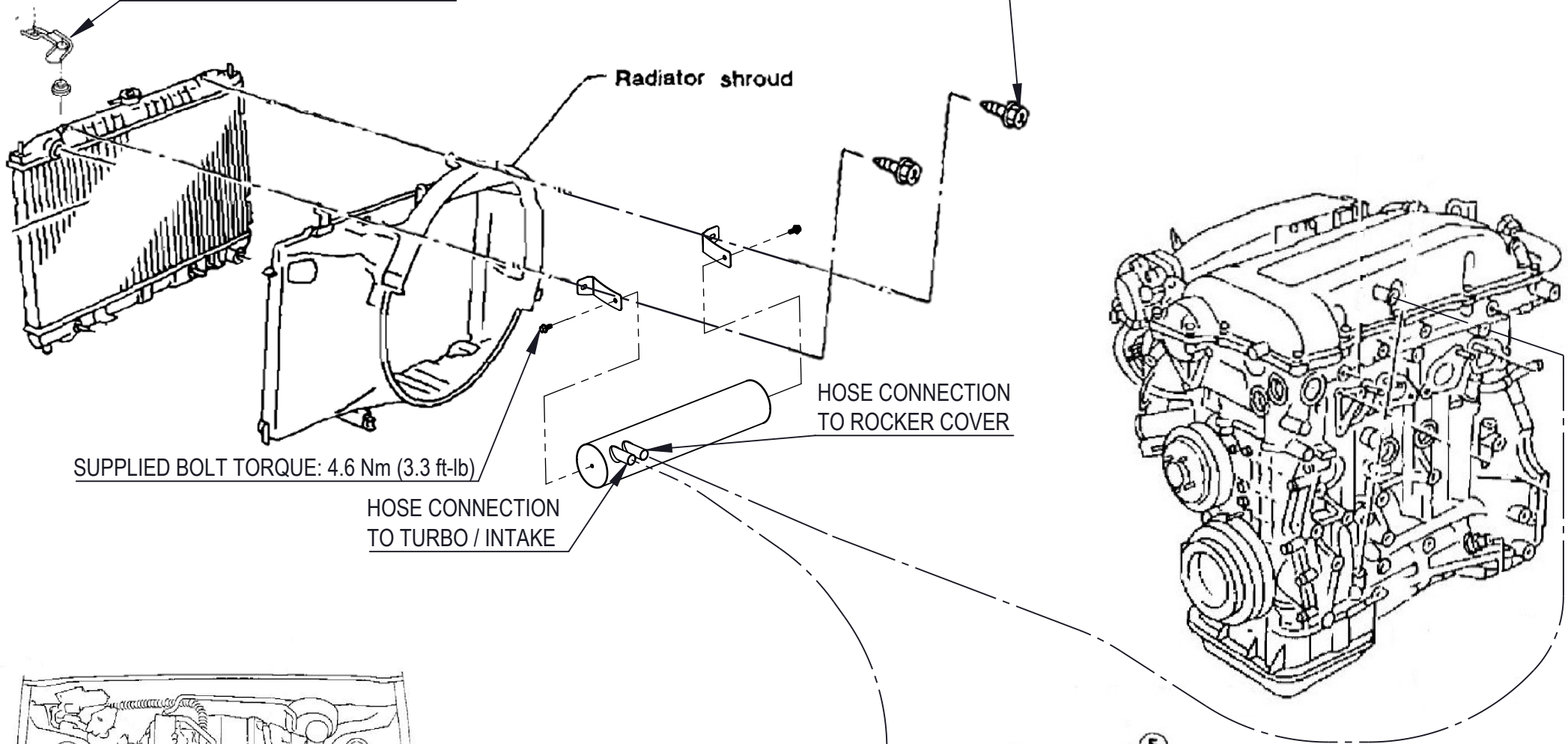

SUPPLIED BOLT TORQUE: 4.6 Nm (3.3 ft-lb)

HOSE CONNECTION TO TURBO / INTAKE

HOSE CONNECTION TO ROCKER COVER

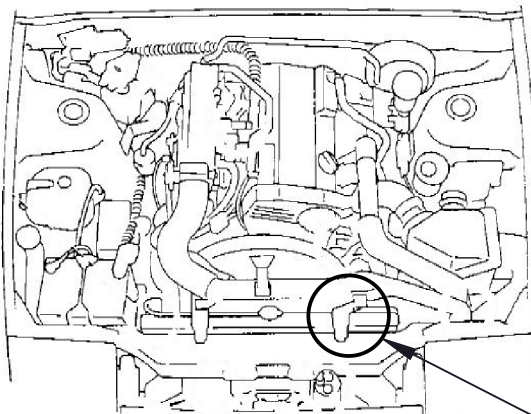

FOR SOME S13 MODELS, THIS INTAKE PIPE MOUNT BRACKET NEEDS TO BE TRIMMED BACK LEVEL TO THE RADIATOR ON THE ENGINE SIDE OR SEE GKTECH S13/180SX CNC MACHINED TOP RADIATOR BRACKETS

