

CLCH-BRCE

1. Clean the clutch pedal bracket by removing rust and paint at all locations which you intend to weld.

2. Install the clutch brace onto the existing bracket from above. To do this the bracket must be removed from the vehicle and disconnected from the master cylinder. It may help to rotate the brace counterclockwise as it is inserted (when viewed in the image on the right).

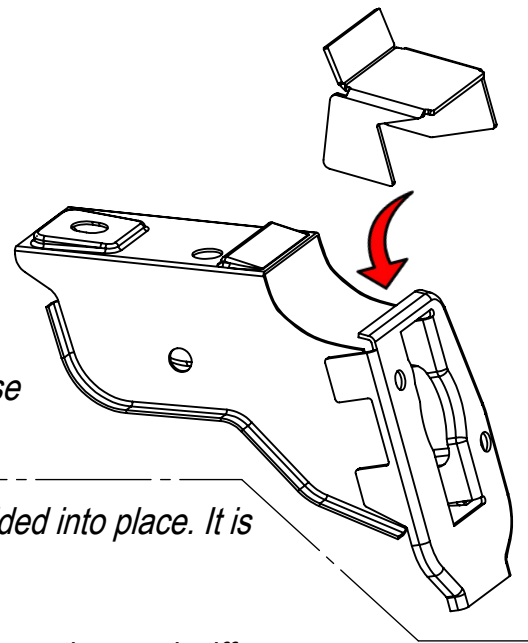

3. Once the brace is located onto the bracket, it should then be tack welded into place. It is recommended to tack in three locations to ensure it is held firmly.

4. Finally, tack welds can be made at each of the marked locations to strengthen and stiffen both the brace and the OEM bracket.

