

350Z-TOEX

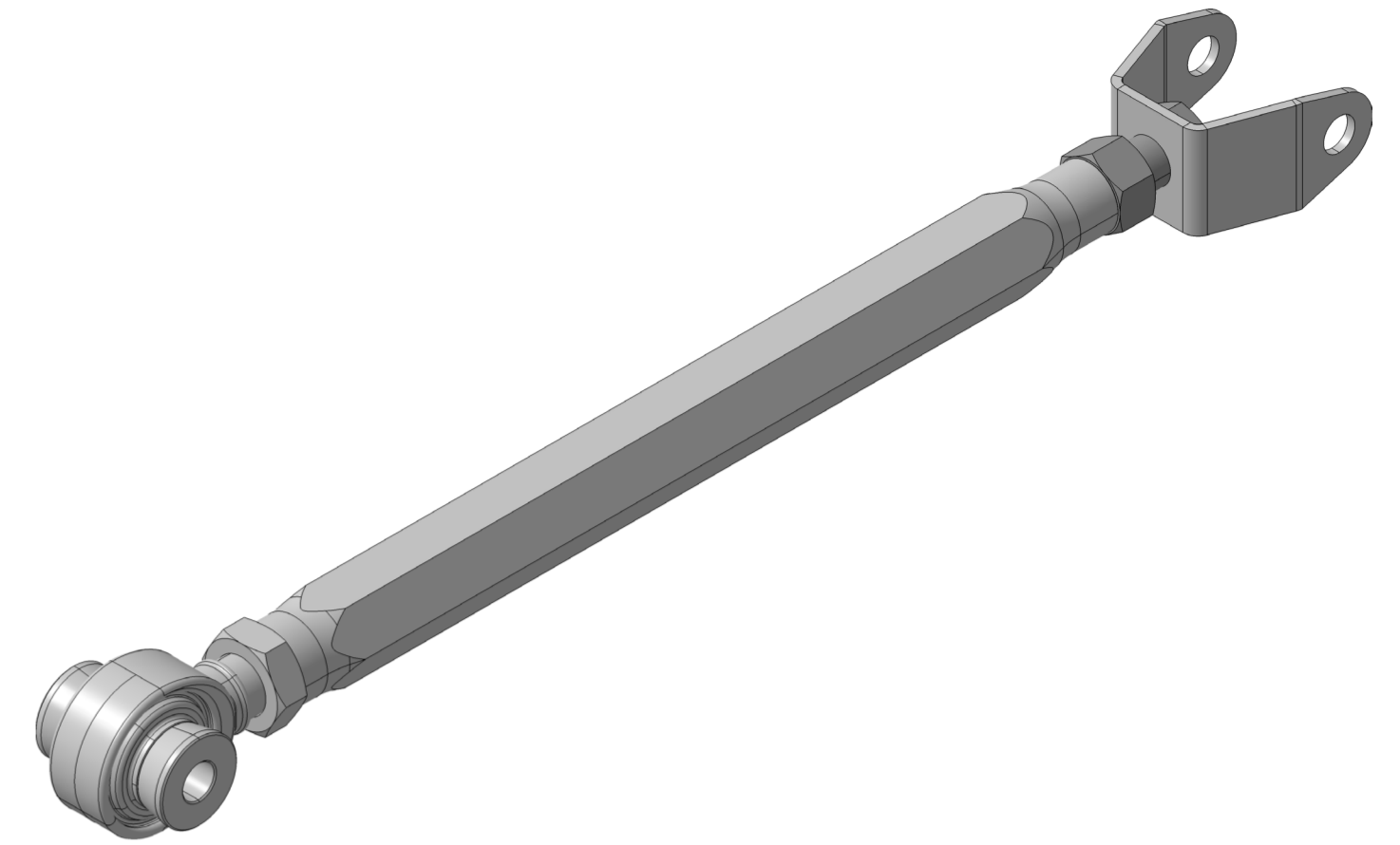

OEM BOLT TORQUE: 72,5 Nm (53 ft-lb)

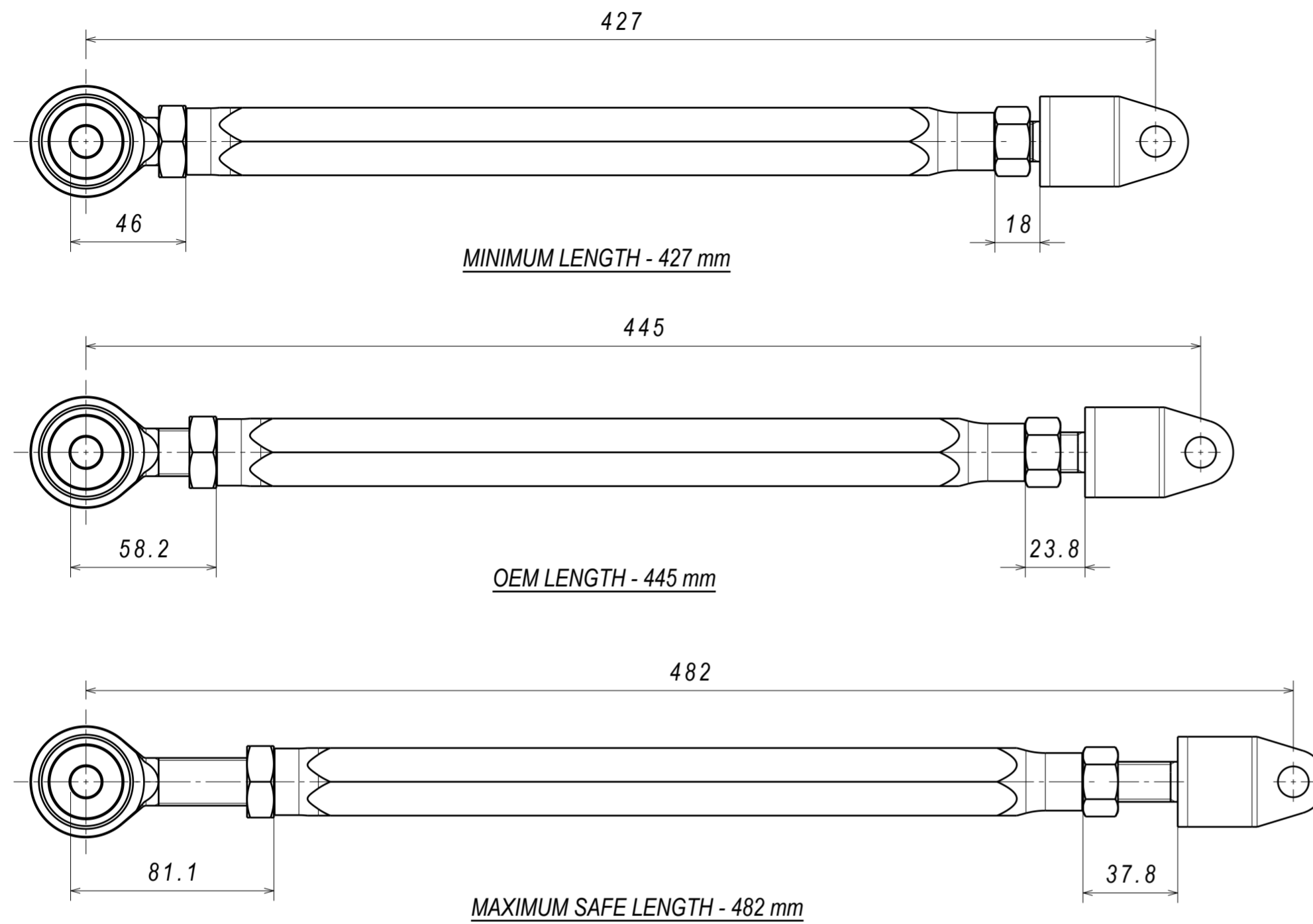
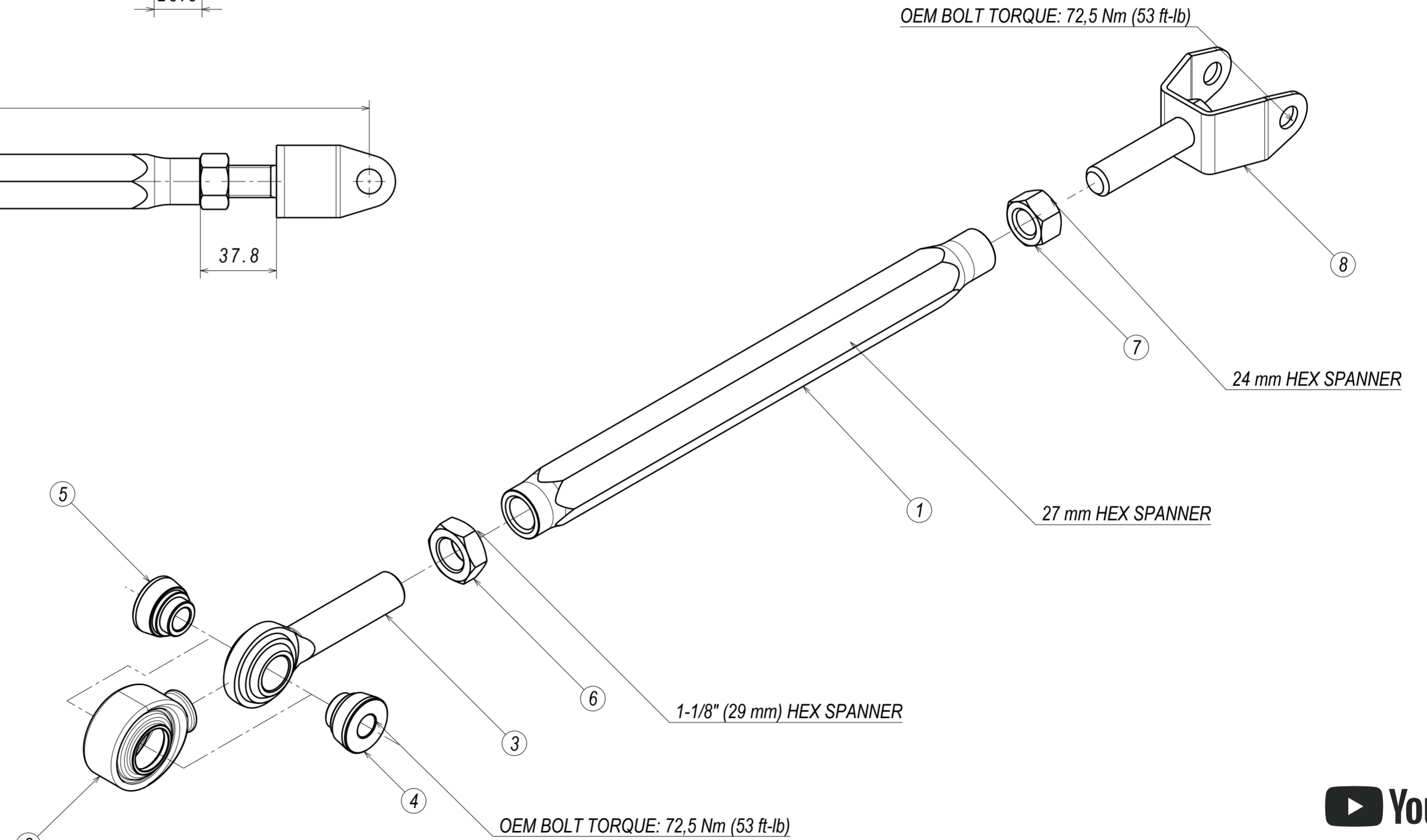

CRITICAL!

CHECK FOR ROD END BEARING ALIGNMENT
AFTER TIGHTENING THE ADJUSTING MECHANISM
ROD END TO BE PERPENDICULAR TO THE SPACERS

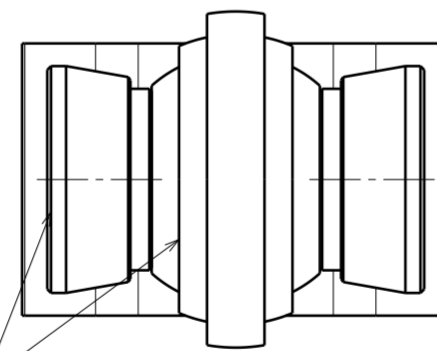

7	350Z TOE LINK CLEVIS WELDING ASM	1
6	NUT M16	1
5	LH 3/4-16 ASTM A563 GRADE A ZINC STEEL JAM NUT	1
4	SPACER M12x50	2
3	ROD END PCML12TES	1
2	QA1 PCML12TES BOOT REV2	1
1	350Z TOE LINK BAR	1
PC NO	COMPONENT NAME	QTY

