

350Z-TOEB

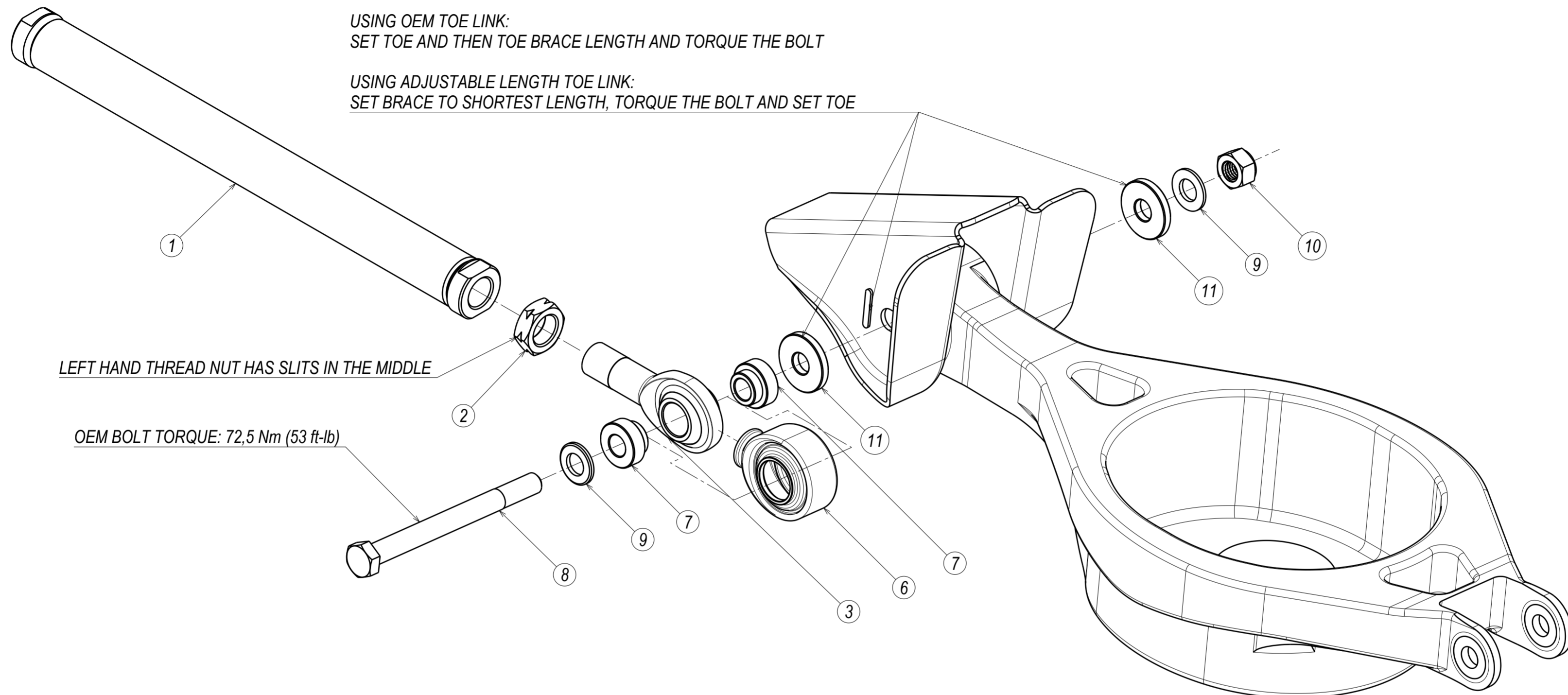

11	NISSAN ECCENTRIC LOCKOUT WASHER	4
10	DIN 985-8 M12x1.75-10 NYLON LOCKING NUT	2
9	ISO 7089 WASHER 12x24 STEEL GRADE A	4
8	ISO 4014 BOLT M12x130 10.9 ZN	2
7	SPACER 1 PCML12T 12ID 40W	4
6	QA1 PCML12T BOOT REV2	2
5	ROD END BEARING PCML12T-RH	1
4	ASME B18.2.2 3/4-16 UNF 3B STEEL THIN	1
3	ROD END BEARING PCML12T-LH	1
2	NUT 3/4-16 UNF 3B LH	1
1	350Z TOE LINK BRACE WELDING ASM	1
PC NO	COMPONENT NAME	QTY

