

MINIMUM LENGTH

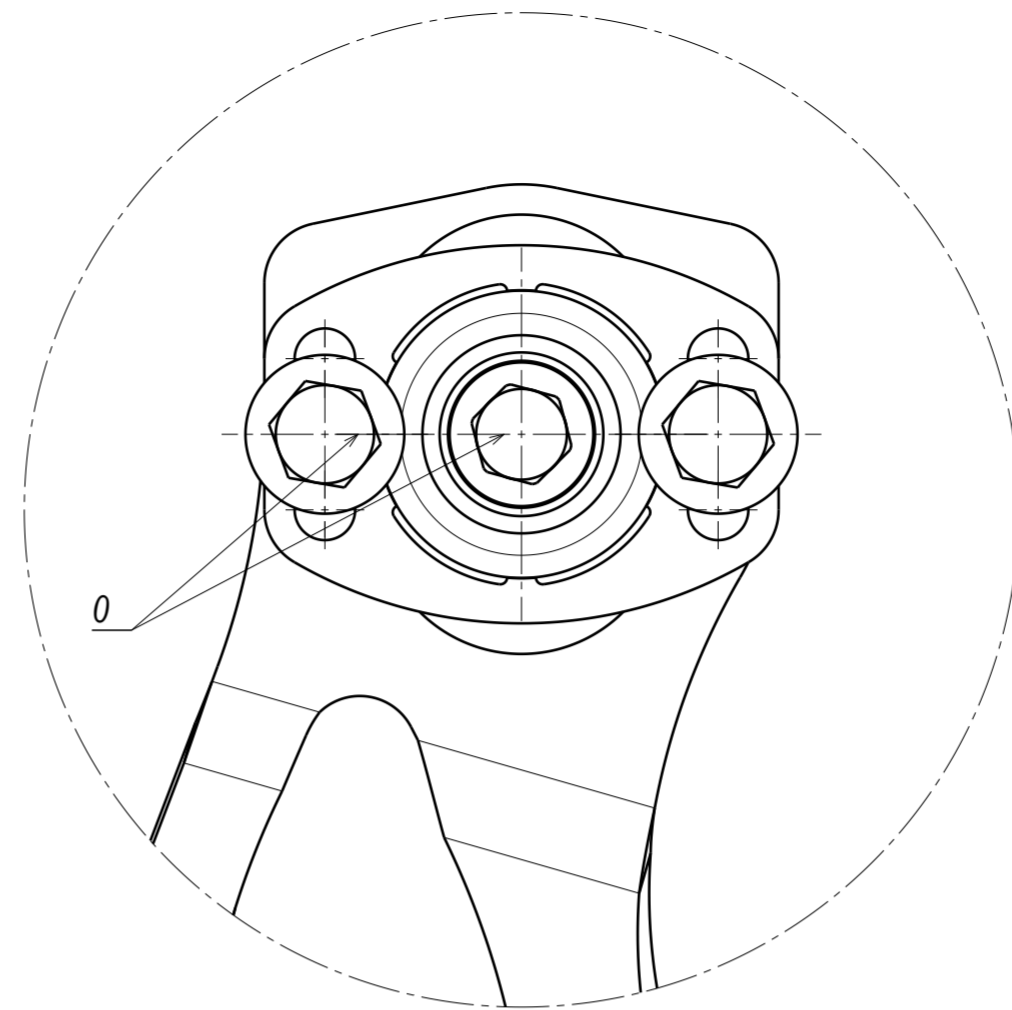

OEM LENGTH

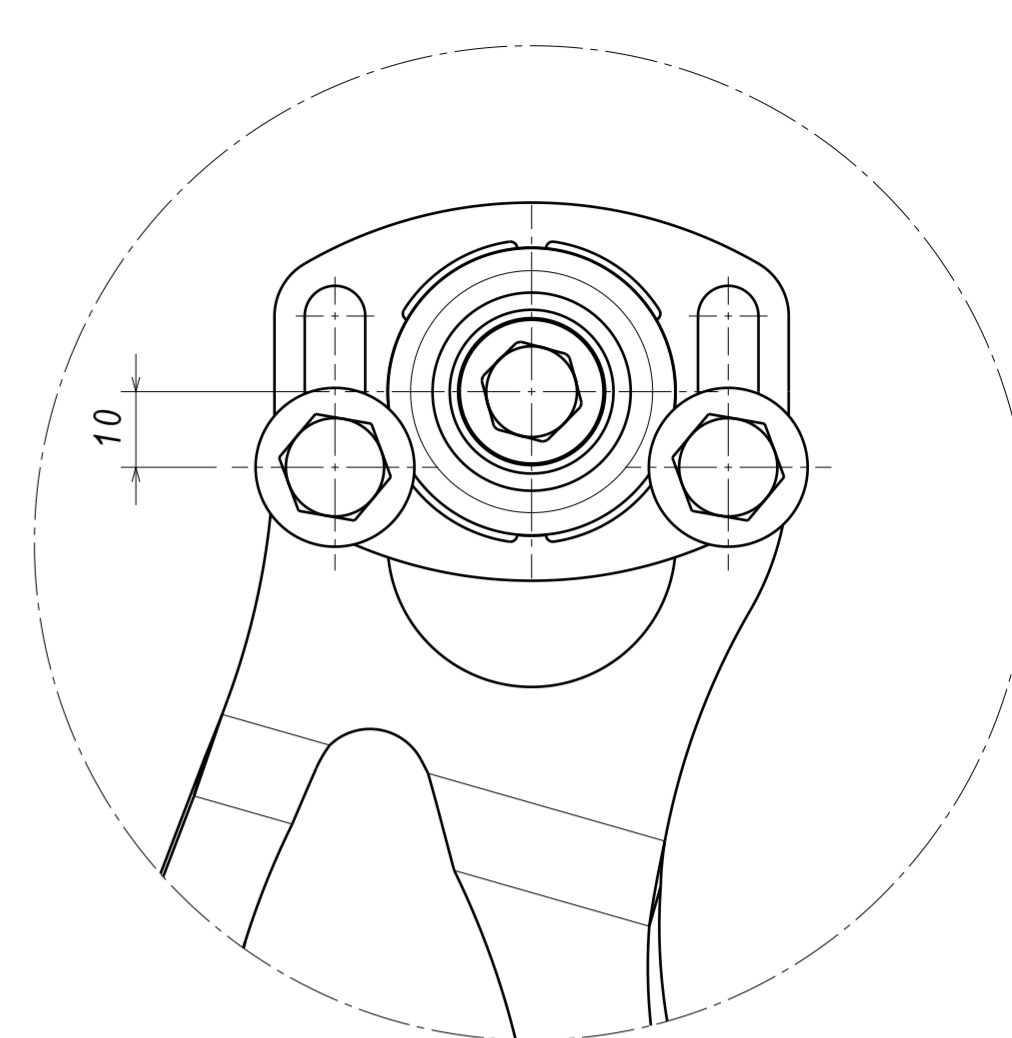

MAXIMUM LENGTH

BOLT TORQUE: 36 Nm (27 ft-lb)

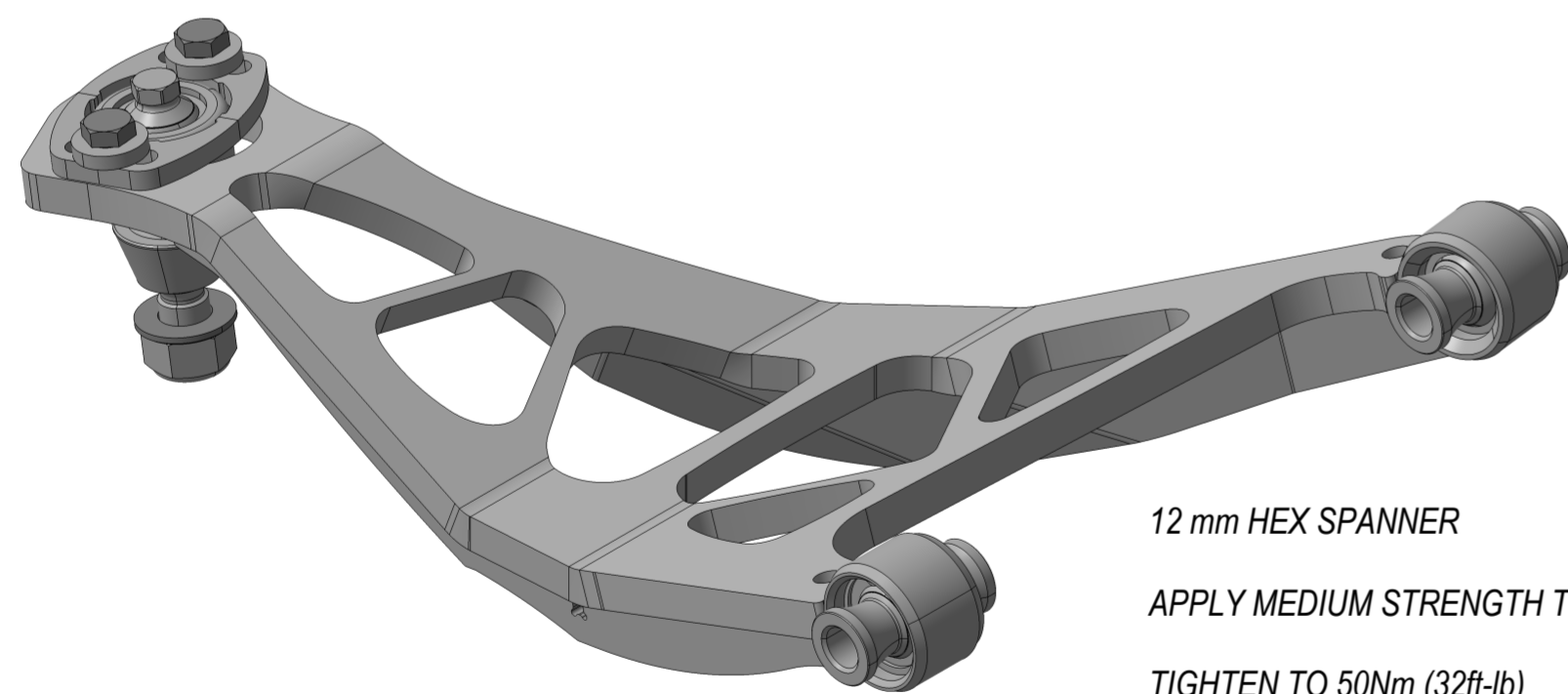

12 mm HEX SPANNER

APPLY MEDIUM STRENGTH THREAD LOCK (LOCTITE 243)

TIGHTEN TO 50Nm (32ft-lb)

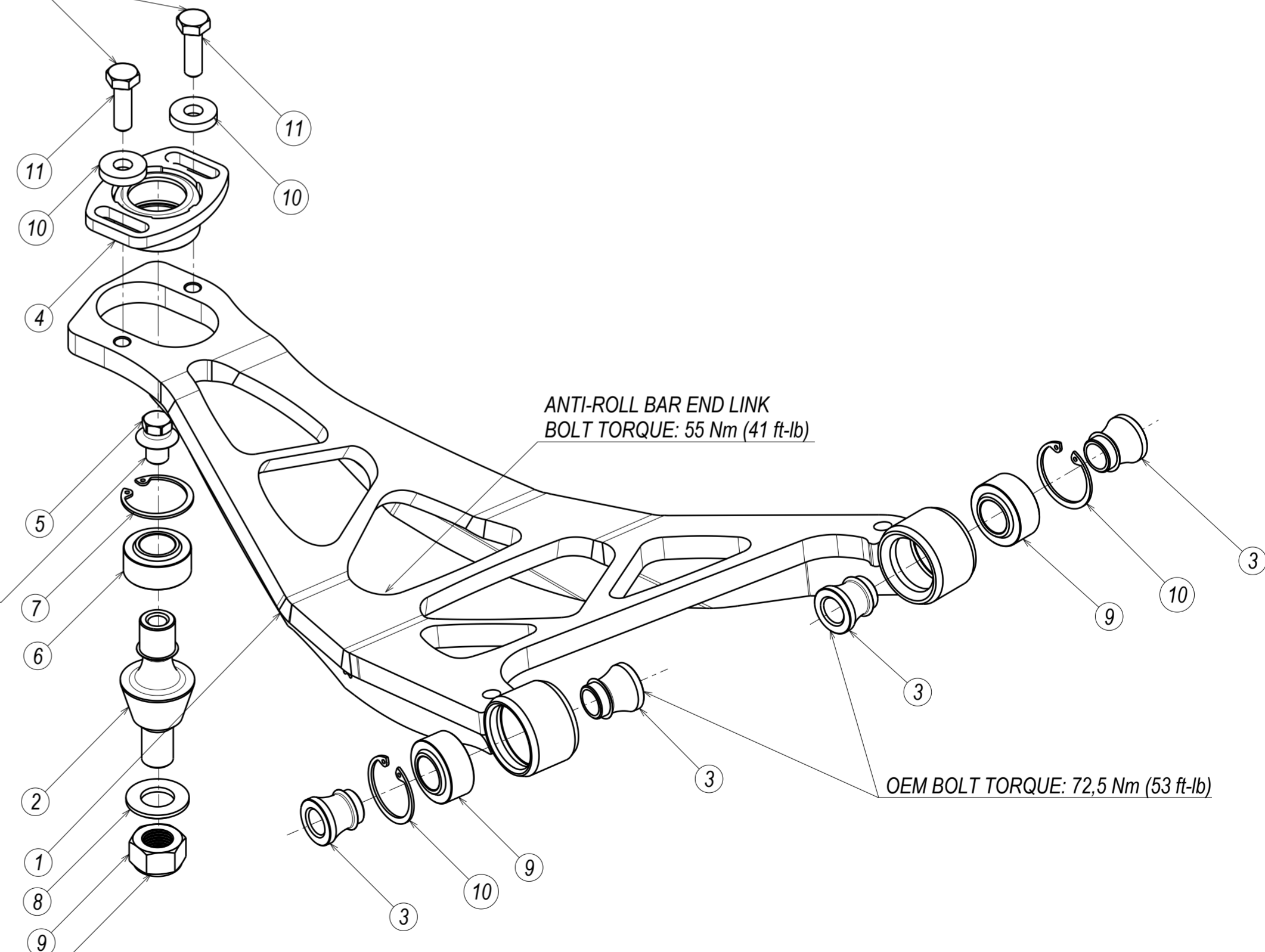

ANTI-ROLL BAR END LINK
BOLT TORQUE: 55 Nm (41 ft-lb)

OEM BOLT TORQUE: 72,5 Nm (53 ft-lb)

OEM BOLT TORQUE: 85 Nm (62 ft-lb)

11	ISO 4017 M8x20 HEXAGON HEAD GRADE A 10.9	2
10	DIN 7349 8x21 THICK WASHER	2
9	DIN 985-8 M14x1.5 NYLON LOCKING NUT	1
8	ISO 7089 WASHER 14x28 PLAIN GRADE A ZN HOT	1
7	RETAINING RING DIN 472 30x1.2	3
6	QA1 SPHERICAL BEARING COM10T	3
5	350Z FRONT TOP A-ARM BEARING BOLT	1
4	350Z REAR TOP A-ARM CAMBER ADJUSTER	1
3	COM10T HIGH MISALIGNMENT SPACER M12x19x50	2
2	350Z REAR TOP A-ARM TAPERED BOLT	1
1	350Z REAR TOP A-ARM WELDING ASSEMBLY R/H	1
PC NO	COMPONENT NAME	QTY