

# 350Z-FLNK

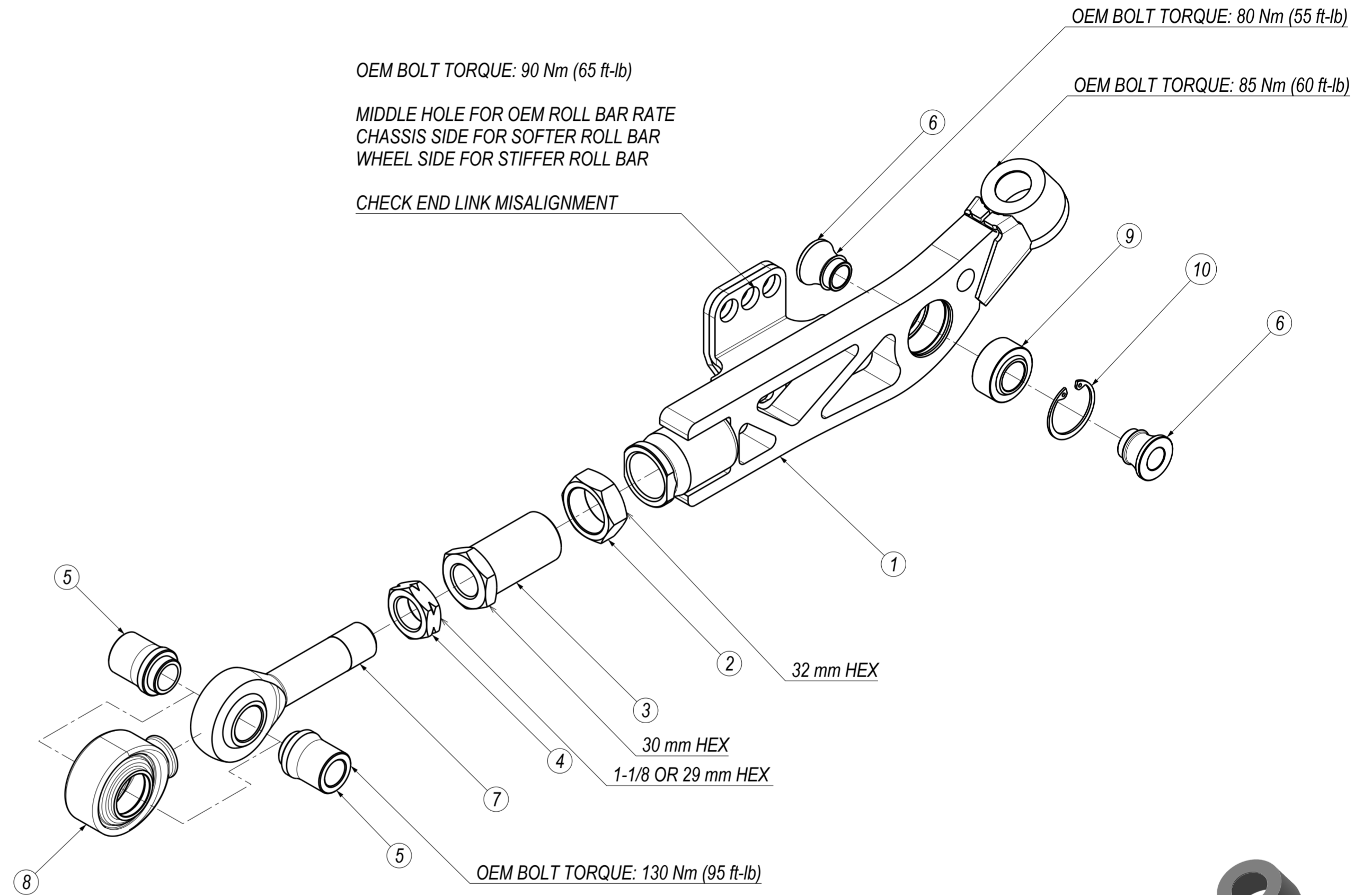
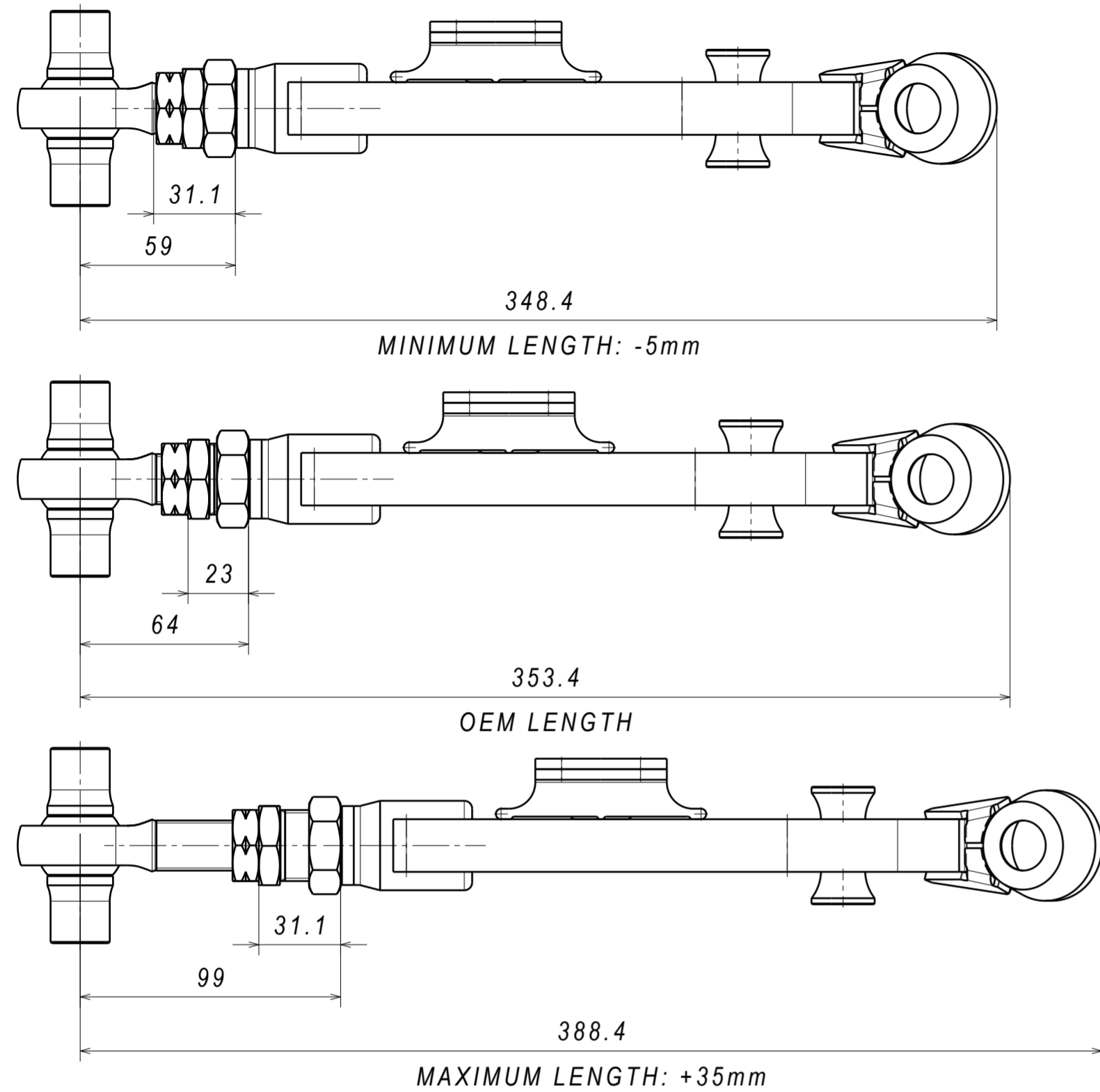

10	DIN 472 30x1.2 RETAINING RING STEEL	1
9	QA1 SPHERICAL BEARING COM10T	1
8	QA1 PCML12T BOOT REV2	1
7	ROD END PCML12-TES	1
6	SPACER - COM10T 12x45	2
5	SPACER PCML12T - 75x14	2
4	NUT 3/4-16 UNF 3B L/H	1
3	FLCA VERNIER SLEEVE	1
2	FLCA M27x2 NUT	1
1	350Z FRONT LINK WELD ASM - R/H	1
PC NO	COMPONENT NAME	QTY

## CRITICAL!

CHECK FOR ROD END BEARING ALIGNMENT  
AFTER TIGHTENING THE ADJUSTING MECHANISM  
ROD END TO BE PERPENDICULAR TO THE SPACERS

