

350Z-CMBR

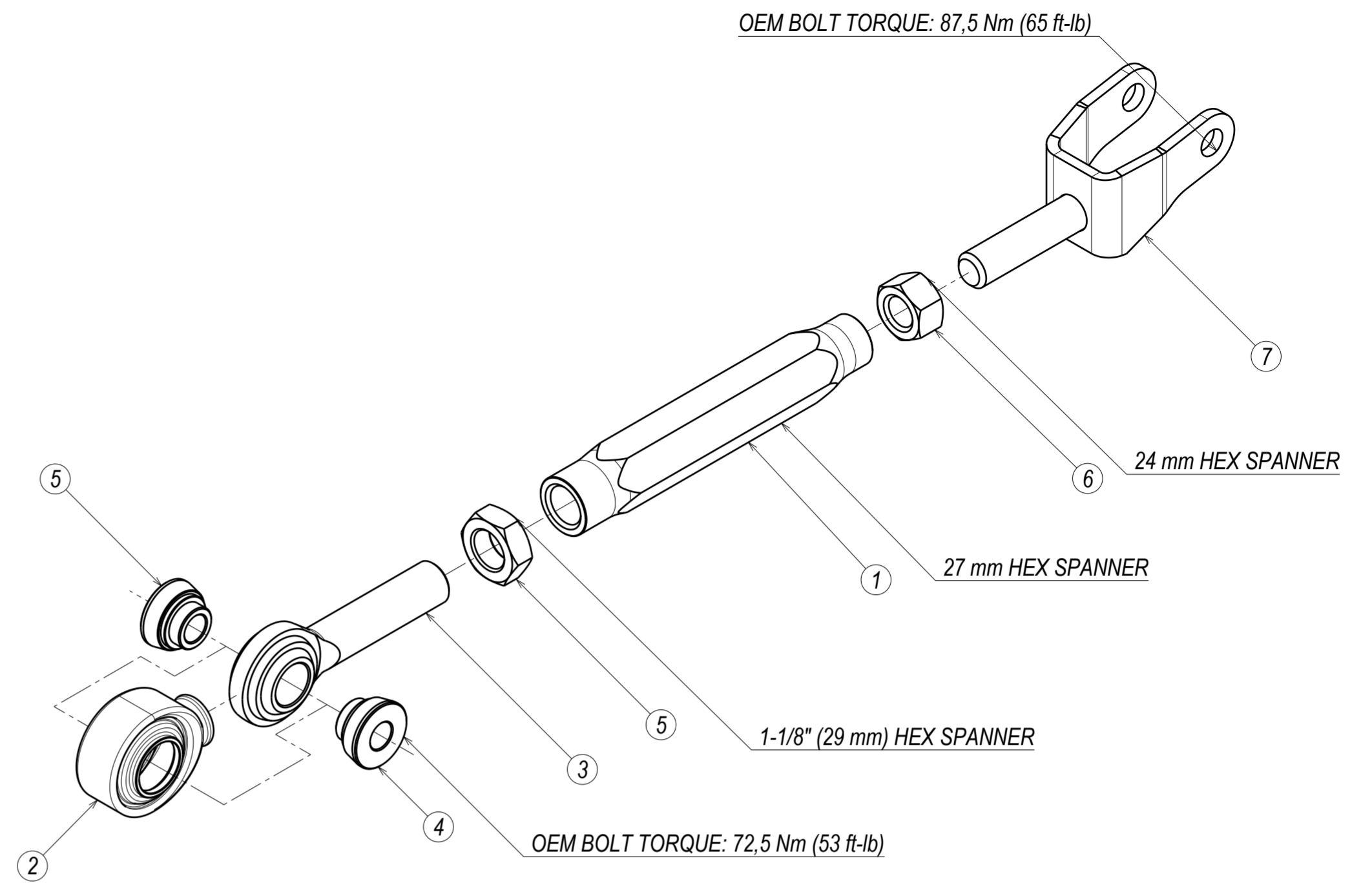
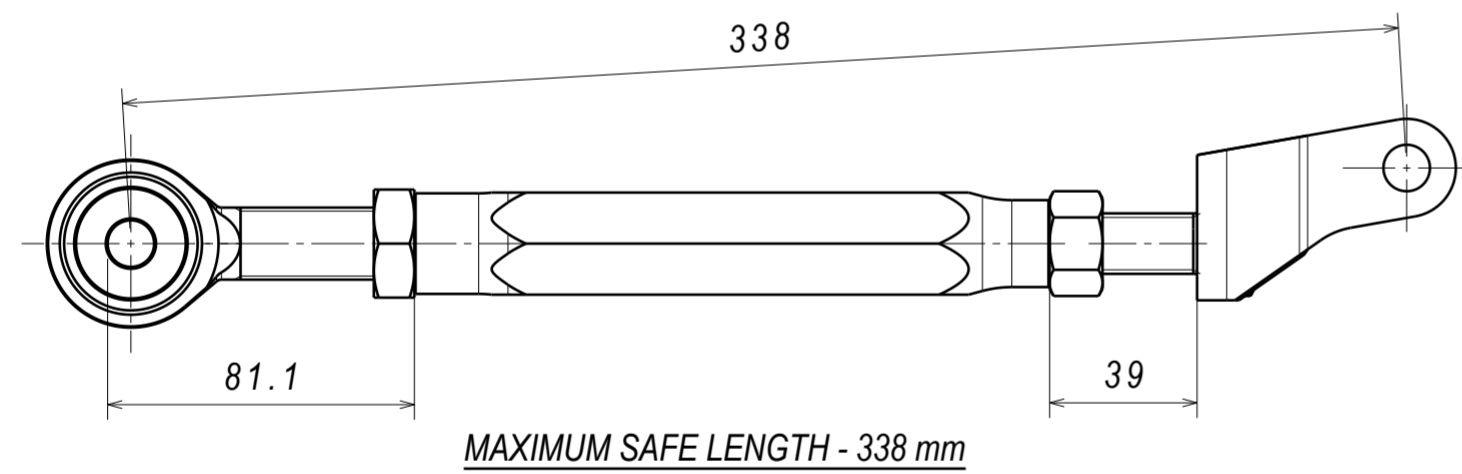
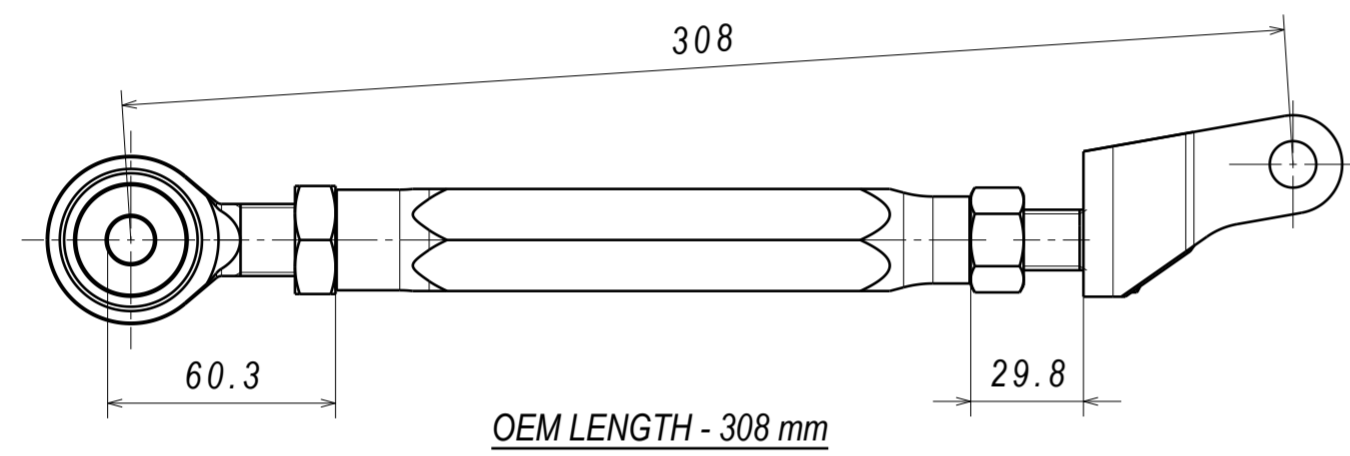
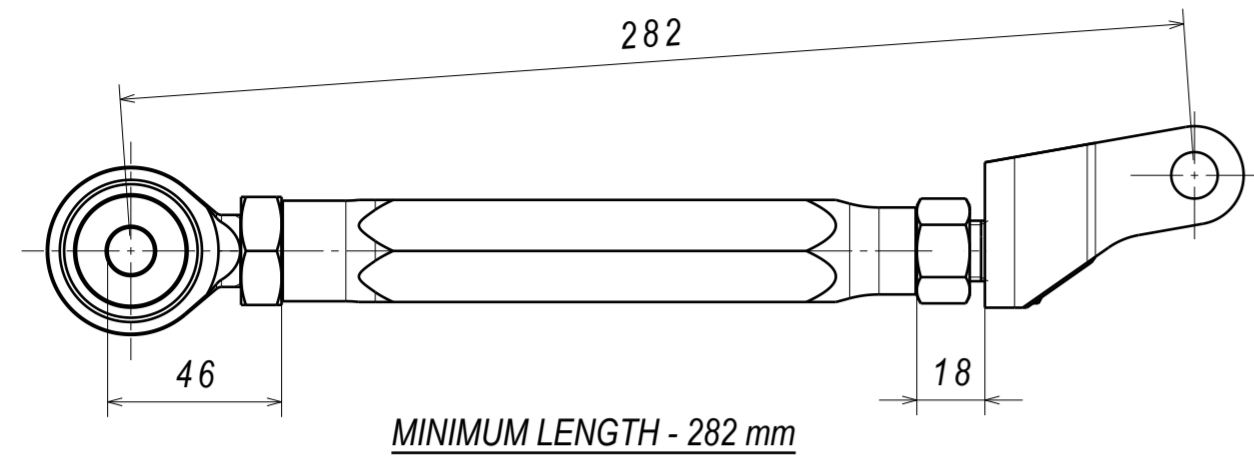

7	350Z CAMBER LINK CLEVIS WELDING ASM	1
6	NUT M16	1
5	LH 3/4-16 ASTM A563 GRADE A ZINC STEEL JAM NUT	1
4	SPACER 19x12x45	2
3	ROD END PCML12TES	1
2	QA1 PCML12TES BOOT REV2	1
1	350Z CAMBER LINK BAR	1
PC NO	COMPONENT NAME	QTY

CRITICAL!

CHECK FOR ROD END BEARING ALIGNMENT
AFTER TIGHTENING THE ADJUSTING MECHANISM
ROD END TO BE PERPENDICULAR TO THE SPACERS

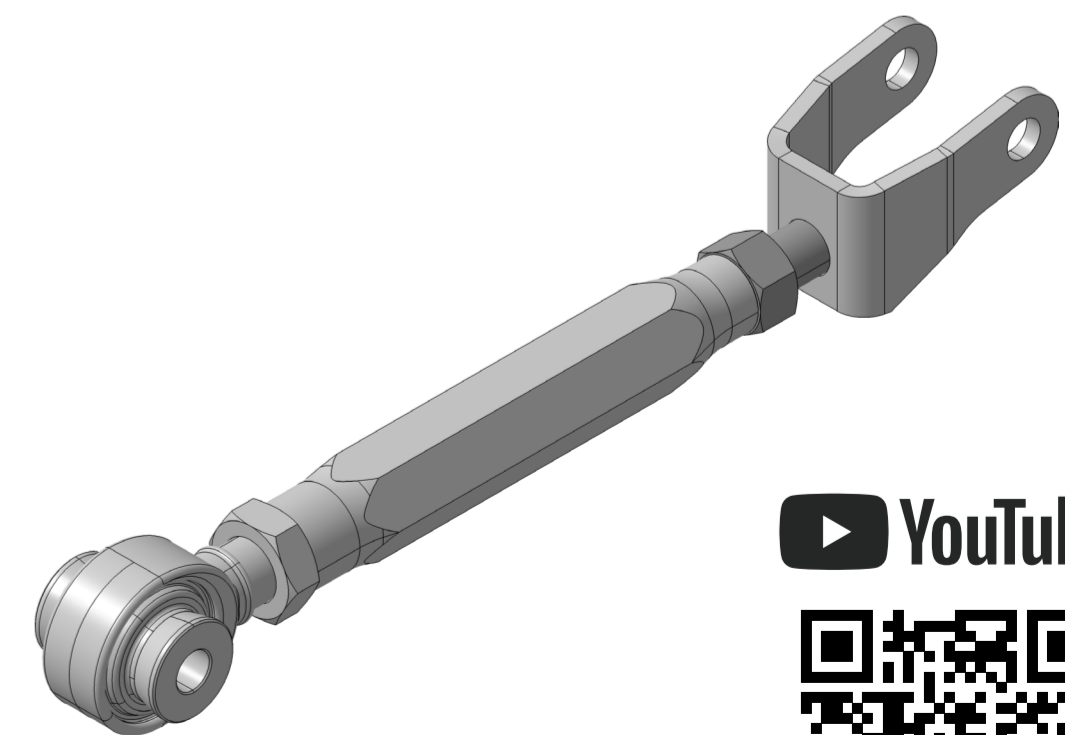
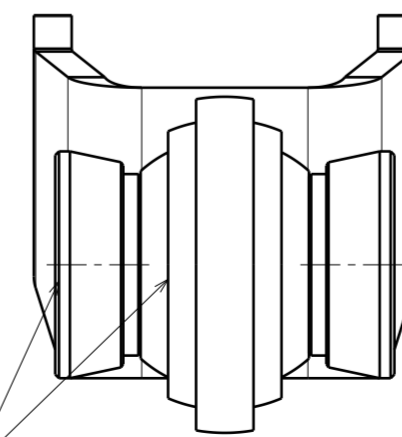

YouTube

