

S145-RRLC

1. Remove from the vehicle and clean the rear lower control arms (RLCA's) by removing rust and paint at all locations which you intend to weld.

2. Test fit into the LCA's (The reinforcement should sit on the flange at the edge of the LCA and NOT down in the gap). Once you are happy with the fitment, tack weld the reinforcements into place.

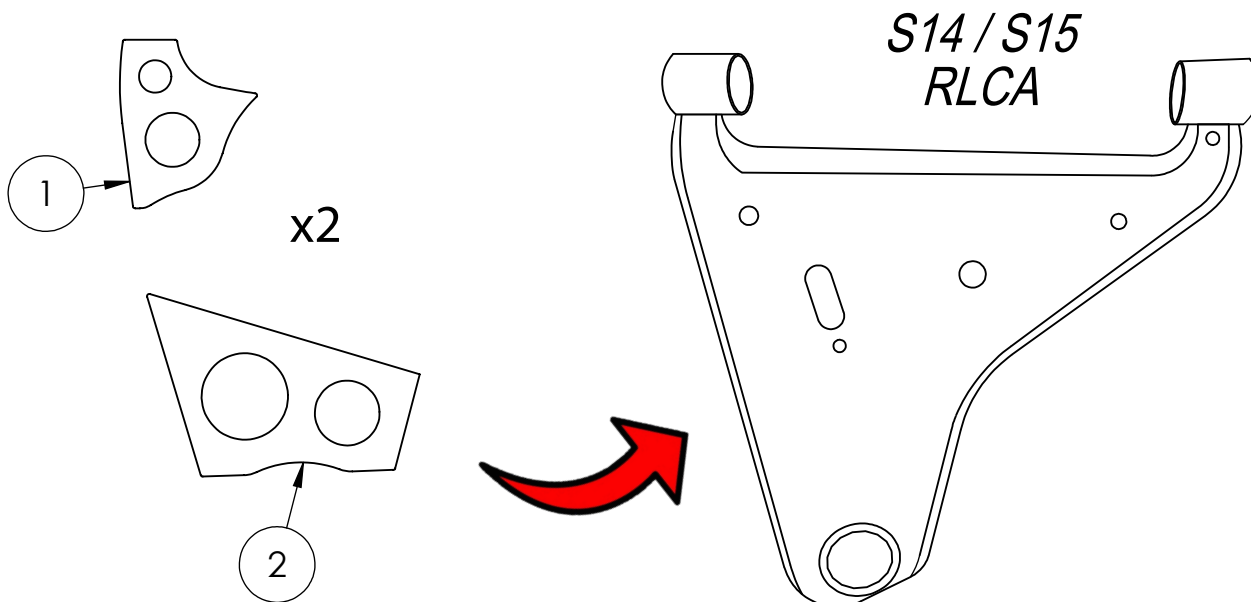

3. Following the completion of the tack welds, the remainder of the stitch welds can be completed at the locations highlighted below.

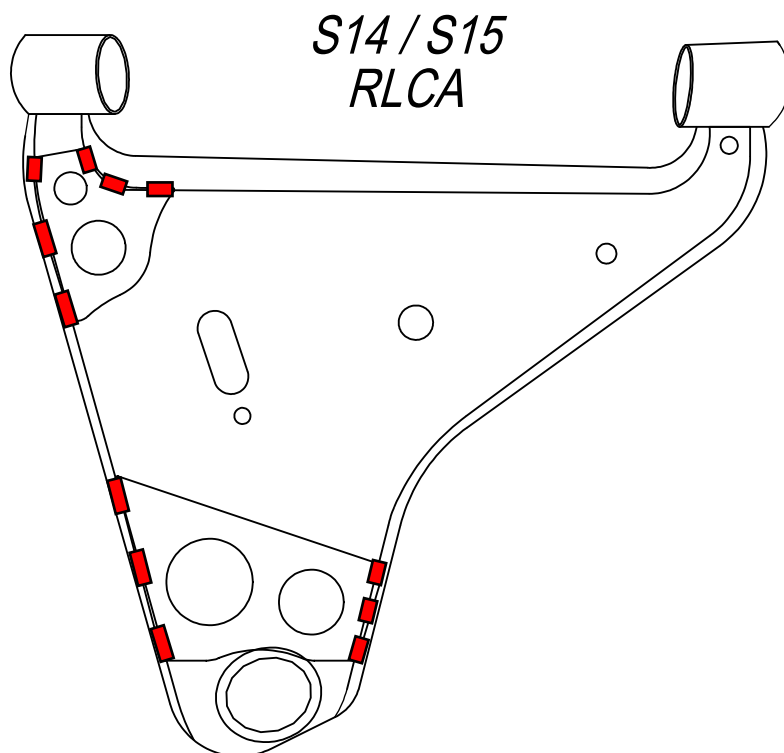

4. Paint the RLCA's to inhibit rust and corrosion, then reinstall in the vehicle.

ITEM NO.	DESCRIPTION	QTY.
1	INNER TRAILING RLCAR	2
2	OUTER RLCAR	2